



Industrial Fork Lifter



Powerful dual-cylinder lifting action

2,000lbs Lift Capacity

Adjustable width fork system

Heavy Duty Bearings for long life

Self-contained power pack. Just plug it in!

Adjustable safety guard



The Perkins Industrial Lifter is a ready-to-operate heavy duty lifting system for any application you can imagine. From refuse handling & recycling, to bulk material handling & machine loading, this dumper does it all! The system comes with a set of forklift-grade forks with adjustable slide, a complete hydraulic package with built in controls, and a sliding guard rail that increases worker safety. Simply anchor to floor and plug in and you're ready to work! Available in custom dumping heights for your custom application.

Model D74900

Patent Pending An ISO 9001:2000 Company
Specifications subject to change without notice

Check out our website!
WWW.PERKINSMFG.COM

Perkins Manufacturing Company
737 Oakridge Drive
Romeoville, IL 60446
Local (708) 482-9500
Fax (708) 354-5878
Email: tuckaway@perkinsmfg.com



Specifications

Stand must be bolted to floor using concrete anchor bolts (not included)

Comes with a 220/440 volt pump with built-in hand control valve. Other power requirements & electric push-button controls are available on request.

Entire unit comes painted standard Safety Yellow for high visibility. Other colors optional.

All steel construction for lasting durability

Completely customizable or choose from one of our standard lifters. Ask for a free quote from our engineers.

Lockout key access is optional.

1-year limited warranty on stand and controls.

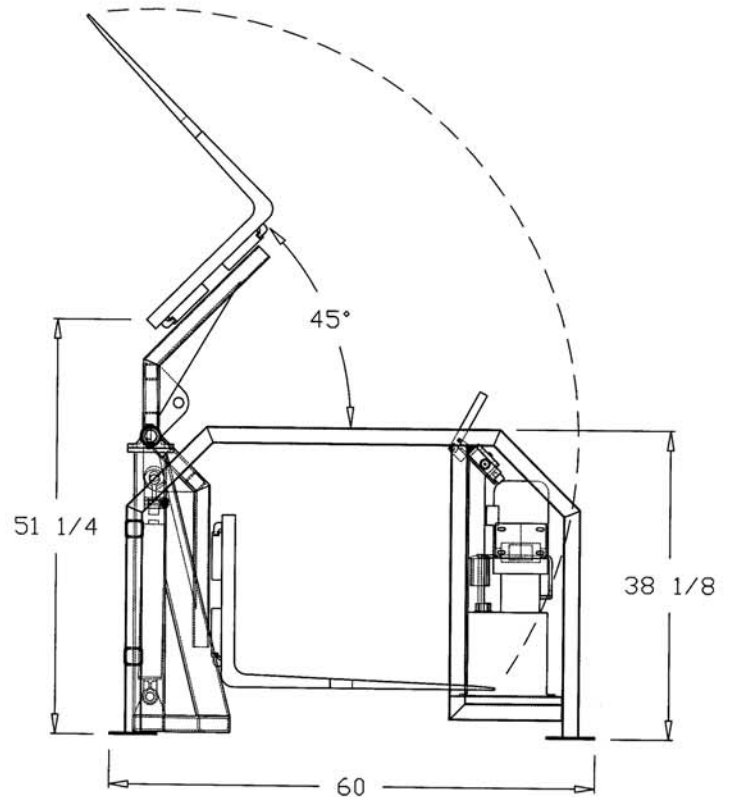
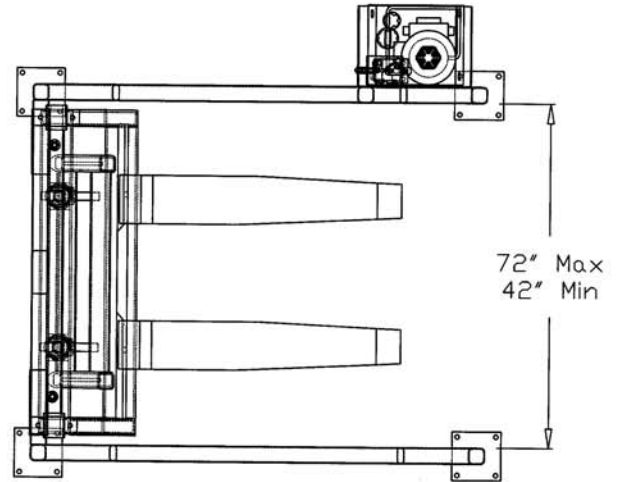

Check out our website!
WWW.PERKINSMFG.COM

Perkins Manufacturing Company
737 Oakridge Drive
Romeoville, IL 60446
Local (708) 482-9500
Fax (708) 354-5878
Email: tuckaway@perkinsmfg.com

Model D74900
Patent Pending An ISO 9001:2000 Company
Specifications subject to change without notice