



Installation, Service &
Operational Manual
Model PAS2.5
Single Automated Side Loader



PAS2.5 Specifications

Cart Compatibility	ANSI Compatible Refuse Carts. From 30 to 96 Gallons in size. Maximum Efficiency achieved when using ANSI Type "G"
Typical Mounting Application	Low/Medium entrance Side Loader Refuse Truck.
Tipper-Bar Compatible?	No
Flow Rate Requirement	10-12 gpm
Cycle Time	10-12 seconds (full cycle)
Recommended Pressure Setting*	2,100 psi to lift Maximum weight capacity
Weight Capacity**	400 lbs
Dump Angle	50 degrees from the horizon
Mounting Height (Ground to Top of Pivot Weldment)	58"
Reach	68"
Approximate Unit Weight (not counting packaging)	1850 Lbs
Hydraulic Package	Sold separately
Controls and Electrics	Sold Separately
Warranty	1-year ***

Perkins regularly makes product improvements. Specifications are subject to change without notice.

* Actual pressure required to lift a load can vary.

** Do not lift more than the recommended amount printed on the cart by the cart manufacturer or damage or injury may result.

*** See Warranty page enclosed in this manual for full details of coverage



ORIENTATION OF LEFT AND RIGHT HAND SIDES

To eliminate any confusion when discussing “left” and “right”, please see graphic below. Left and Right is that of the observer, when viewing the machine from the front of the machine.

**AS VIEWED WHEN LOOKING
AT THE FRONT OF THE LIFTER.**

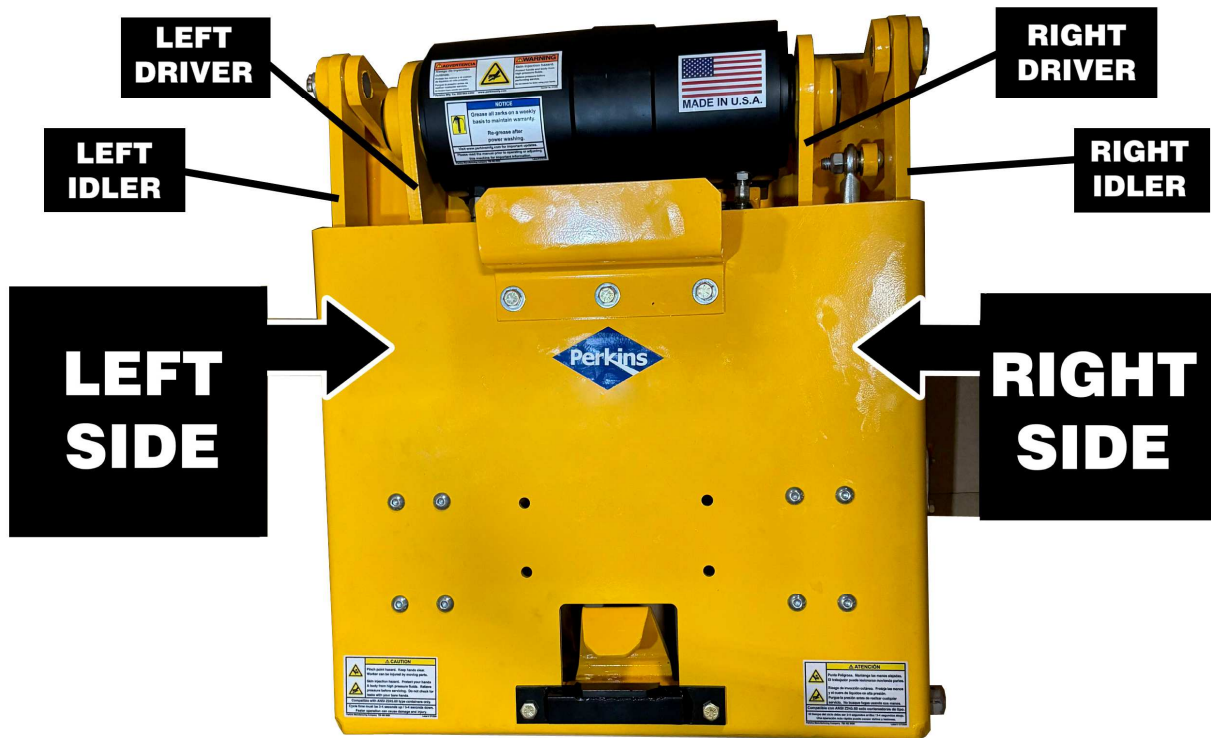

Drivers are always connected to the actuator hubs.

Idlers are not connected to the actuator.

Lifter shown is for example only. Your model may vary in appearance.



Perkins Manufacturing Company
Creators of the TuckAway® Cart Lifter
www.perkinsmfg.com

800-882-5292

Revised: 11/15/23
Addendum

Overall Dimensions

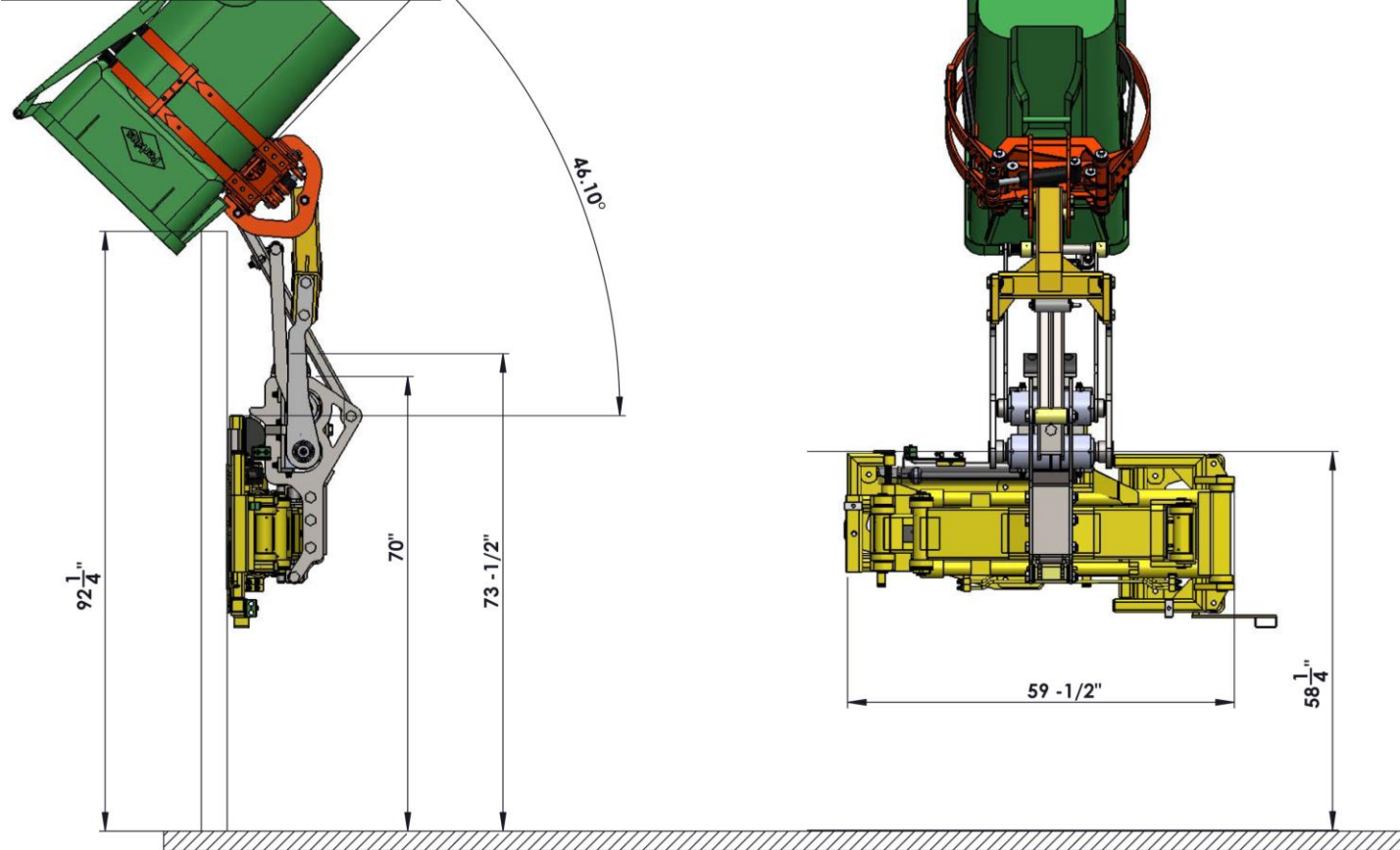
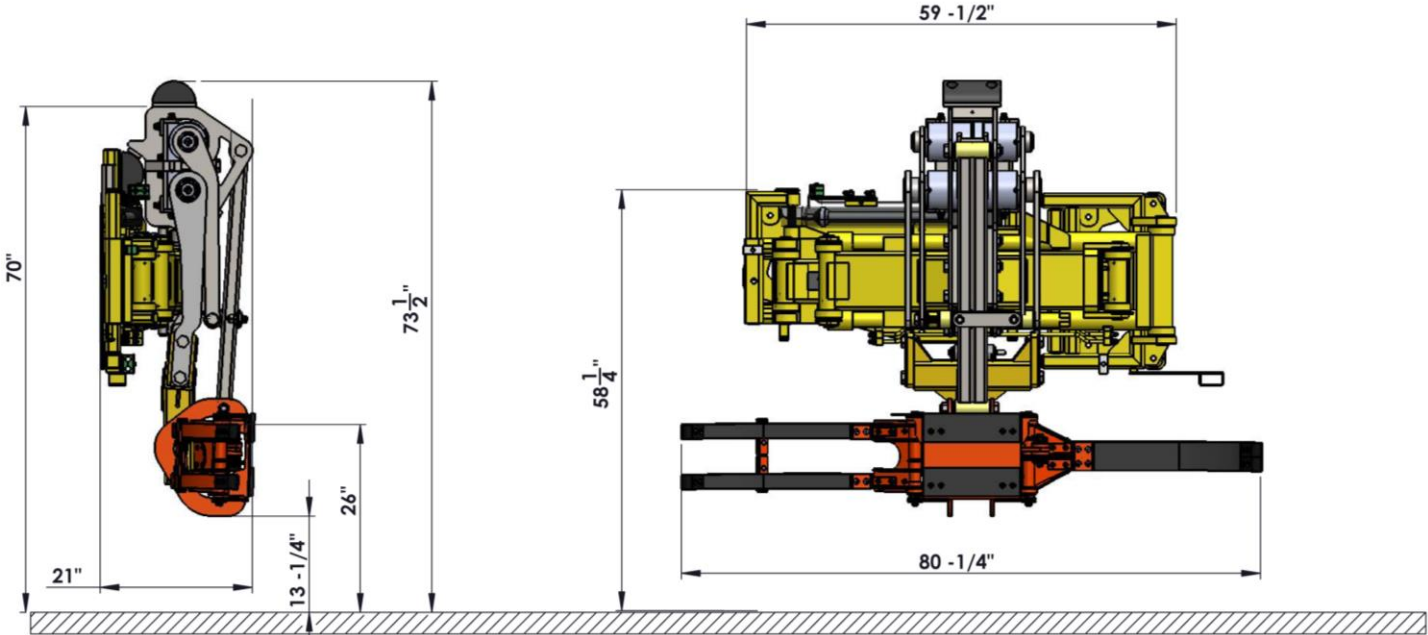

Overall Dimensions

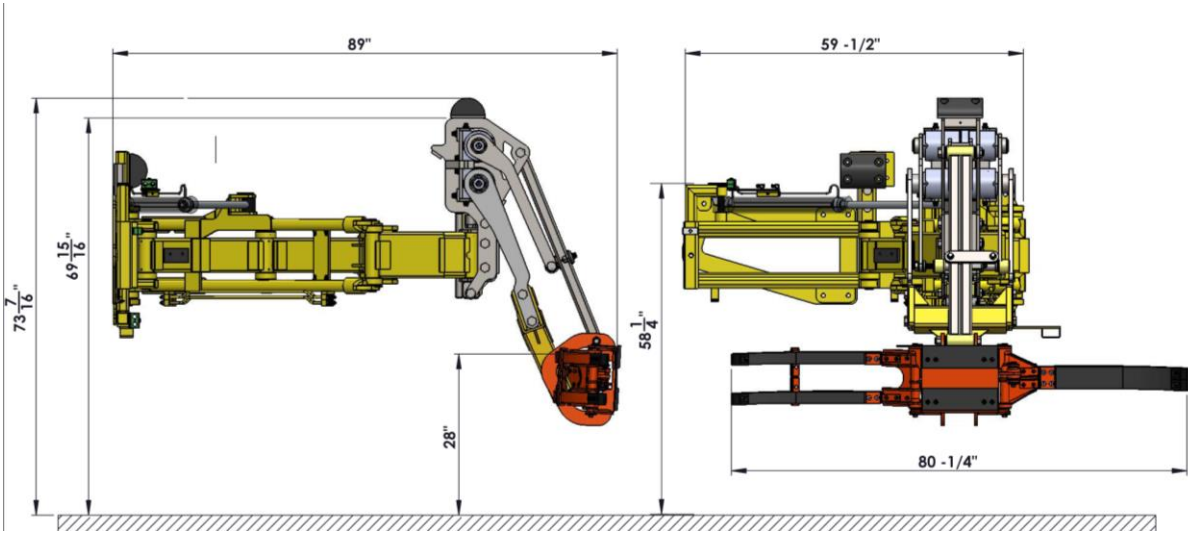

Perkins regularly makes product improvements. Dimensions are subject to change without notice.

Cart Compatibility



THE PAS2.5 HAS BEEN DESIGNED TO LIFT THE WIDEST VARIETY OF ANSI COMPATIBLE REFUSE CARTS POSSIBLE. ABOVE ARE EXAMPLES OF ACCEPTABLE CARTS, RANGING FROM 30 TO 96 GALLON IN SIZE. MAXIMUM ROUTE EFFICIENCY IS ACHIEVED USING THE CORRECT TYPE OF AUTOMATED-COMPATIBLE CART (ANSI TYPE "G").



THERE EXISTS A WIDE VARIETY OF GARBAGE CARTS COMMONLY AVAILABLE AT RETAIL STORES. THESE CARTS MAY BE LIFTED BY THE AUTOMATED SYSTEM. RESULTS MAY VARY WITH THE TYPE OF CART USED. FACTORS TO CONSIDER WHEN USING STORE-BOUGHT CARTS:

- 1) THE PLASTIC MATERIAL AND STRUCTURE OF STORE-BOUGHT CARTS ARE INTENDED FOR HAND LOADING OPERATIONS, NOT FOR AUTOMATED MACHINE PICK-UP. CART BREAKAGE MAY OCCUR.**
- 2) UNLIKE THE CARTS ABOVE, LIDS ON STORE BOUGHT CARTS ARE TYPICALLY NOT ATTACHED. LIDS MAY BE DROPPED INTO THE REFUSE BIN OR THE GROUND, OR MAY STAY LOCKED IN PLACE.**



Overall Scope for Truck Compatibility



Shown, are examples of trucks that may be compatible for the application.

Truck Must be capable to deliver 10-12GPM

The PAS2.5 has been designed to be compatible with the widest variety of semi-automated low entry side loaders. And in especial occasions (see overall dimensions), even high entry side loaders. The truck must have a packer blade that can be controlled from the cab or can be set to run automatically.

The extent of the modifications will vary from simple modifications to considerably alterations, depending on the truck. Factors to consider include the placement and necessary relocation of hydraulic or electric lines, gas or oil tanks, access doors, steps, valves and other equipment that may interfere with the PAS2.5 mounting location. Depending on the vehicle, it may be necessary to modify the access door to clear the Grippers. As a reminder, the structural integrity of the truck must not be compromised, so care should be taken to properly reinforce any areas where steel is removed. Installation of a PAS2.5 is different than ordinary cart lifters; therefore installation should be performed by an experienced mechanic who has received training from Perkins on this type of installation.



Installation Safety

Please read this manual prior to installing, repairing or using this cart lifter.

- ✦ Installation of this equipment requires welding, painting, grinding, torching and working with high- pressure hydraulic systems. Appropriate safety equipment should be used always.
- ✦ Always follow OSHA specified lock-out procedures while working with a truck.
- ✦ This equipment is heavy. Always use proper heavy lifting equipment.
- ✦ Always use a chain or strap to secure the equipment in the upright position during the installation process. Unsecured equipment may fall suddenly causing injury.
- ✦ The terrain to which the equipment is to be installed should be empty of waste. Torching and welding can ignite the waste materials and cause a fire.
- ✦ Do not open/loosen any hydraulic lines unless the system is off and depressurized.
- ✦ Always double-check hydraulic fittings and hoses for tightness prior to reactivating the pump.
- ✦ Always relocate lights that need to be moved due to the position of the equipment to a clear and unobstructed area clearly visible to drivers.
- ✦ All after painting of the equipment after installation is complete should be done with proper ventilation and per local regulations. Do not paint over caution and warning labels.
- ✦ If there are any questions about the proper installation or use of the equipment not covered in the manual, it is recommended to call Perkins at 800-882-5292.



Please be aware of the risks of working with welding equipment and consumables. Always use safety protection equipment. The sparks may ignite fire, always clean the area from flammable material or flammable chemicals, do not weld close to gas lines or on top of electrical cords or installations. Disconnect battery cables from the battery and make sure the vehicle is perfectly grounded prior to attempt to do any weld. Always weld in a ventilated area.



WHEN WELDING, WEAR APPROPRIATE EYE AND SKIN PROTECTION. WELDING LIGHT CAN BLIND. WELDING LIGHT CAN SUNBURN THE SKIN. LONG TERM EXPOSURE TO WELDING LIGHT CAN CAUSE CANCERS. ALWAYS WEAR PPE WHEN WELDING. PROPER PPE SHOULD ALSO BE WORN BY ANYONE IN THE THE WORK ZONE WHO MIGHT ALSO BE EXPOSED.

**WATCH YOUR SPARKS!
HELP PREVENT WILDFIRES**

Precautions to take when you use welding equipment outdoors.

- Remove vegetation from the work area.
- Where vegetation can't be removed, use a sprayer to wet down the work area prior to starting welding operations. Wet a wider area on the down-wind side from the welding location. If working in the same area for an extended period, re-wet the vegetation surrounding the work site.
- Keep water handy.
- Post a fire watch in your area.
- Fire that sparks ignite so that they can be caught while small.
- Avoid parking vehicles in dry grass tall enough to reach the catalytic converter on the underside of your vehicle.



Correct and safe electric welding station

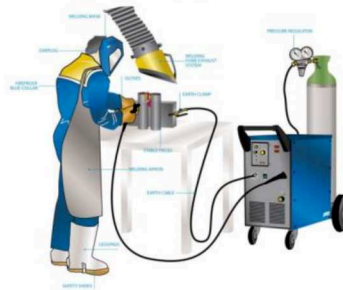

HYDRAULIC SYSTEMS CAN LEAK OUT HIGH PRESSURE WHICH CAN CAUSE SERIOUS INJURY, GANGRENE OR DEATH. DO NOT CHECK FOR LEAKS WITH YOUR BARE HANDS AND AVOID CONTACT WITH LEAKING OIL STREAMS.

HYDRAULIC OIL CAN ENTER THE BLOODSTREAM. SEEK MEDICAL ATTENTION IMMEDIATELY IF YOUR SKIN IS PUNCTURED BY HYDRAULIC OIL.

HYDRAULIC SYSTEMS CAN BECOME HOT (GENERALLY UP TO 170-180 DEG. F.) TO AVOID BURNS, DO NOT TOUCH VALVES, ACTUATORS, CYLINDERS, AND OTHER HOT COMPONENTS, EVEN AFTER THE SYSTEM IS SHUT OFF IT WILL REMAIN HOT AND TAKE TIME TO COOL DOWN.

ALWAYS TURN OFF A SYSTEM BEFORE SERVICING IT. DEPRESSURIZE THE CIRCUIT BY ACTIVATING THE CONTROLS WITH THE SYSTEM OFF TO RELIEVE ANY BUILT UP PRESSURE.

NEVER WORK UNDER A RAISED LOAD. RAISED EQUIPMENT CAN SUDDENLY FALL WHEN A VALVE OR LINE IS OPENED (LIKE A MOUSETRAP). IF THE EQUIPMENT MUST BE SERVICED IN THE RAISED POSITION, SECURE THE EQUIPMENT WITH CHAIN OR STRAP TO HOLD IT UP SAFETY.



Overview of Components (Sold Separately)



Stack Valve Assembly



**JOYSTICK ASSEMBLY
PART # D50262**

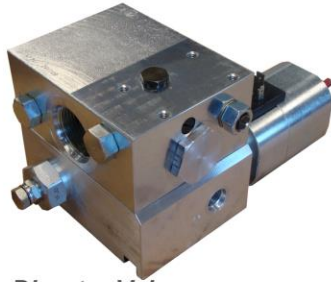

**Diverter Valve
PART # A90190RV**



**Wire Harnesses and sensors:
A91164, D50264, D50215, D50280**



**PTO & Pump
PART # A90821-A90822**



**Control Box
PART # A91166**



PAS2.5 Mechanical System



Centering the PAS2.5

The machine needs to be installed in direction of the hoper facing out. Where is possible the PAS2.5 needs to be centered with the hoper, clearing to the sides and top with any component of the truck that could be located near to the hoper. See image.

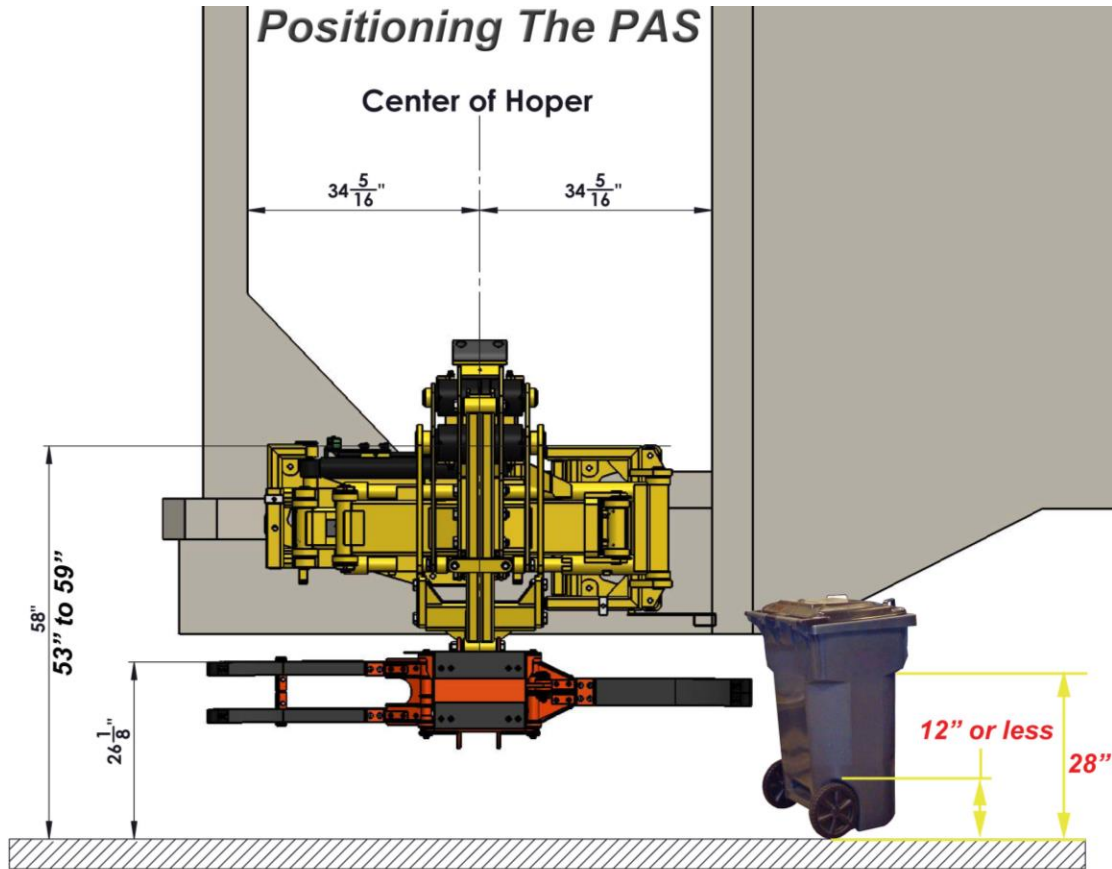

The center of the gripper arm carriage when retracted must align with the center of the hopper opening. If offsetting the lifter to one side or another, make sure there is at least 15" from the center of the gripper carriage to the edge of the opening.

The unit mounting distance from ground to the top of frame is 58". The unit has some gap on mounting the lowest possible is 53" and the highest is 59". The final mounting height of the PAS is dependant on the size of your truck and the existing structures that may be in place. However, for optimal performance, the unit should be mounted as high as possible. Mounting higher allows the garbage to fully discharge from the cart, distributing the waste into the hopper better and allowing more clearance with the packer blade.

The top of the gripper arms, should not be higher than 28" and the bottom of the gripper arm should not be lower than 12" or the gripper arms will not grip carts properly.

If the machine needs to be installed off-center of the hopper, pay attention to the moving parts, machine needs to clear all the truck's components to avoid interference. Watch especially for oil and fuel tanks, fenders, tool boxes, other wiring/cables, doors, etc.



Installation (continuation)

Height Leveling the PAS2.5

To height leveling the unit, truck needs to be placed in a level and clean surface, the tire wheels need to be inflated to the air pressure suggested for truck's manufacturer and the suspension system needs to be well calibrated and properly working (consult your truck's manufacturer to check on this important issues). Once the truck is leveled and in proper compliance with tire wheels and suspension system, prepare the surface where the machine is going to be mounted. The mounting weldments of the machine will need to be properly back supported and welded all around. See the image below for dimensions, consider that, the weight of the machine extended and with 400Lbs of load will make the truck to lower more, make plans for that when mounting.

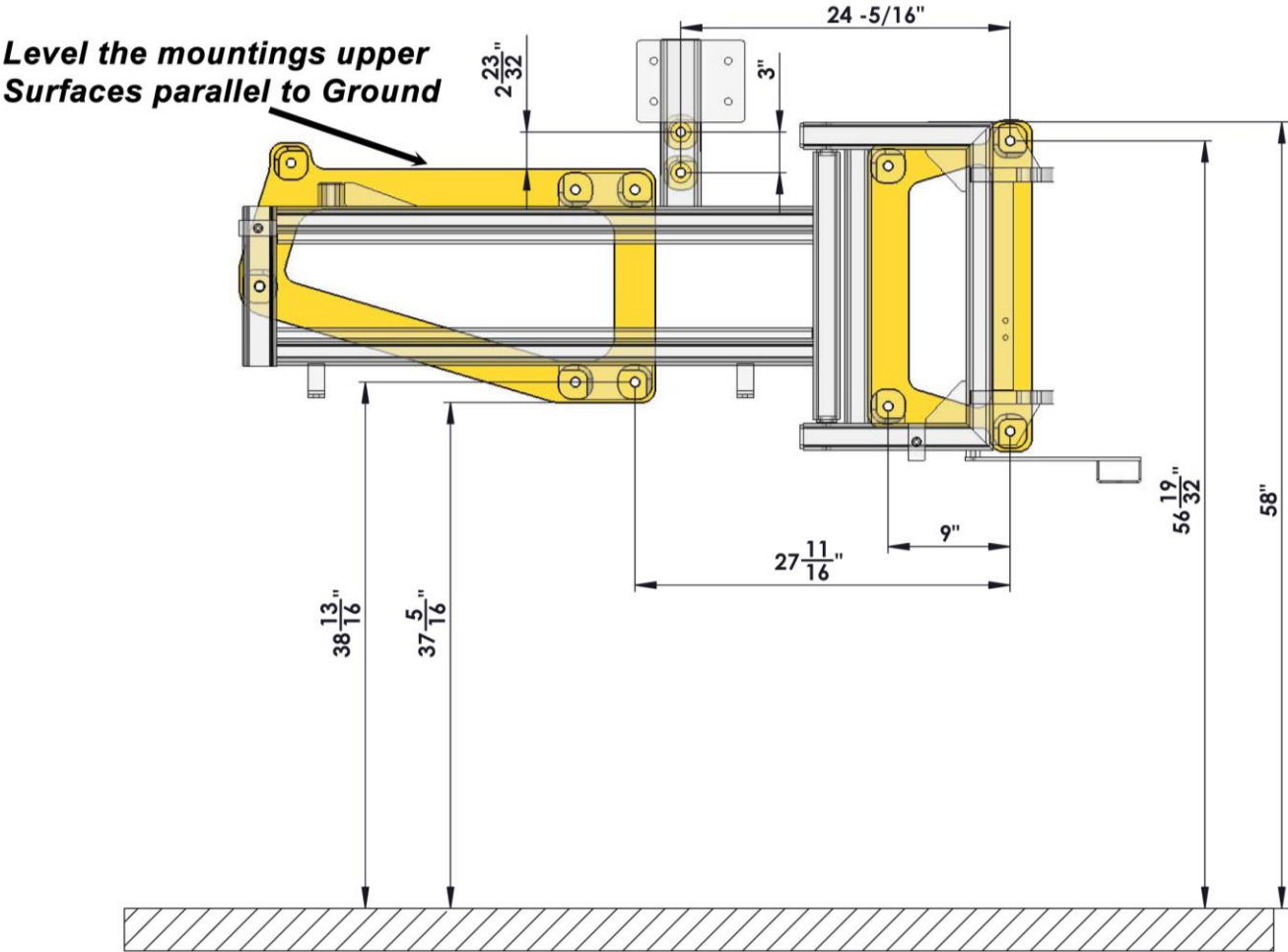

Welding the Back-Mounting Weldment of the PT5100

With the dimensions given above, design and manufacture a back-support tube for the back mounting and tack weld in place. Structural steel tube with at list ¼” of wall or the equivalent can be used. Do not fully weld the back support and back mounting now, only tack weld strong enough to resist the testing process. After the machine is fully validated at the testing, fully weld the back-support tubes and back mounting weldments. See image.

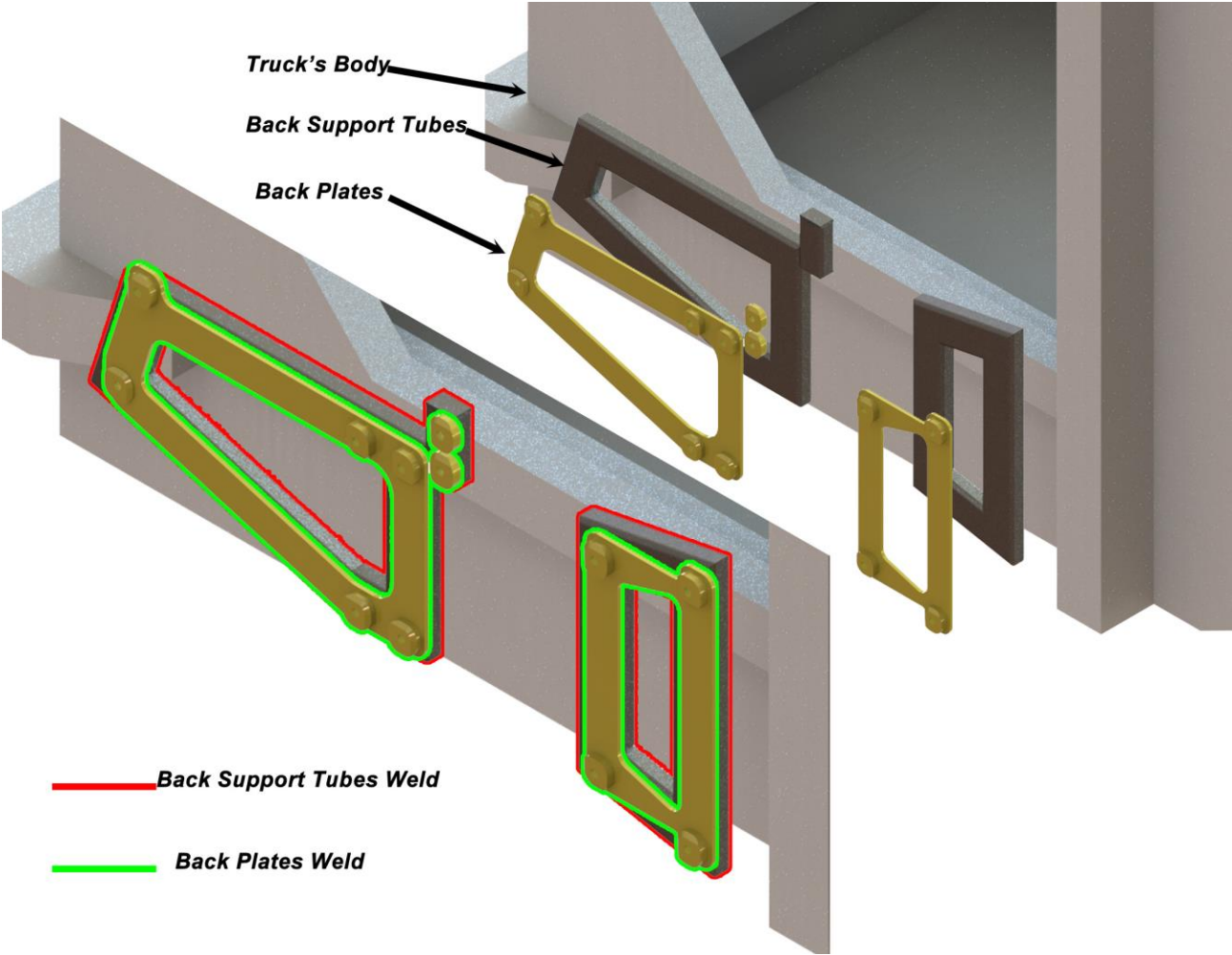

Assembling the Unit

NOTE: Although the unit comes already assembled the following instructions are meant to help with future service to the machine.

NOTE: The best and fastest way to assembly the unit is by completing tasks. For example, all the bearing cases can be inserted all at once, the rubber pad can be installed, subassemblies can be assembled before attaching it to entire assembly, etcetera. However, these instructions will be given in sequence step by step.

Warning! Parts of this machine are too heavy; the use of appropriated heavy lifting equipment is a must. **Do not lift those parts by yourself!**

Once the mounting bases (7), (44), (45) are attached and secure to the truck's body:

Install the mountings (5), (18) and secure them with lock washers (147) and bolts (69) (115)

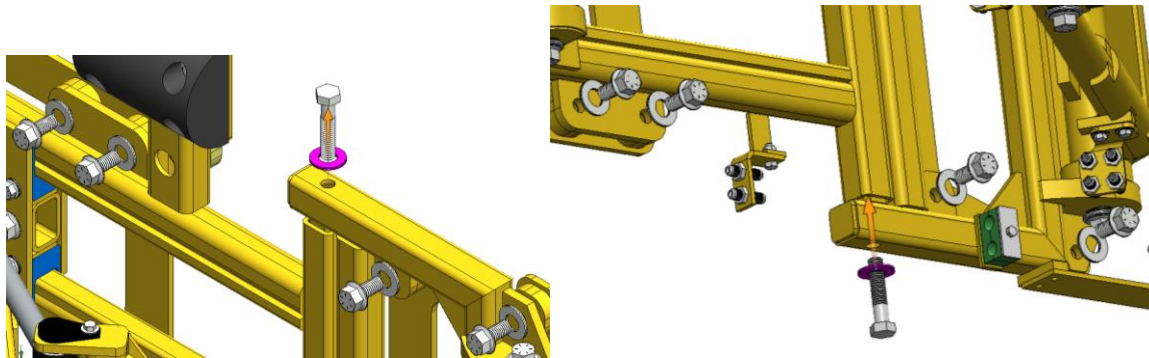

Install the bumper (134) with washers (96) bolts (110) and nuts (105) on the mounting (18). Insert the slide plastics (22) into mounting (18) and trap them between slide weldment (17) and back weldment (16) utilizing bolts (69) (68) lock washers (108) and nuts (141).

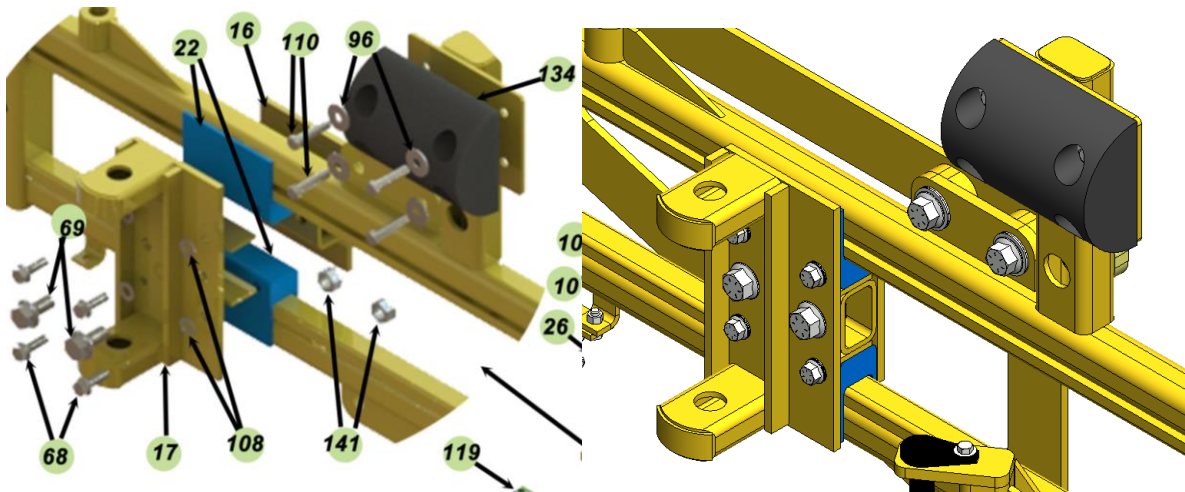

Insert the bearing cases (6) and the rubber seals (19) into their locations at the main pivot weldment (35). Insert the main pivot weldment (35) with the top bearings (6) on it into the mounting (5) align pivot holes and insert pin (14) to retain in place, secure pin (14) top and bottom with retainers (30) lock washers (147) and bolts (69).

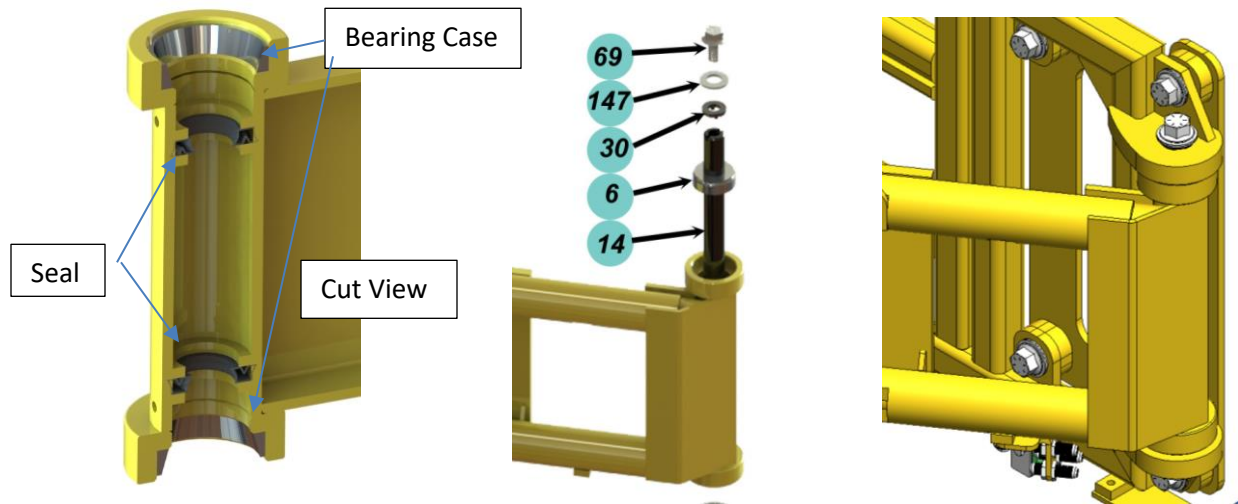

Insert bearing cases (6) and the rubber seals (19) into their locations at the inside tube weldment (23). Insert the inside tube weldment (23) into the main pivot weldment (35) at the center, align holes and insert pin (15) to attach, secure pin (15) with retainer disk (30) lock washer (147) and bolt (69).

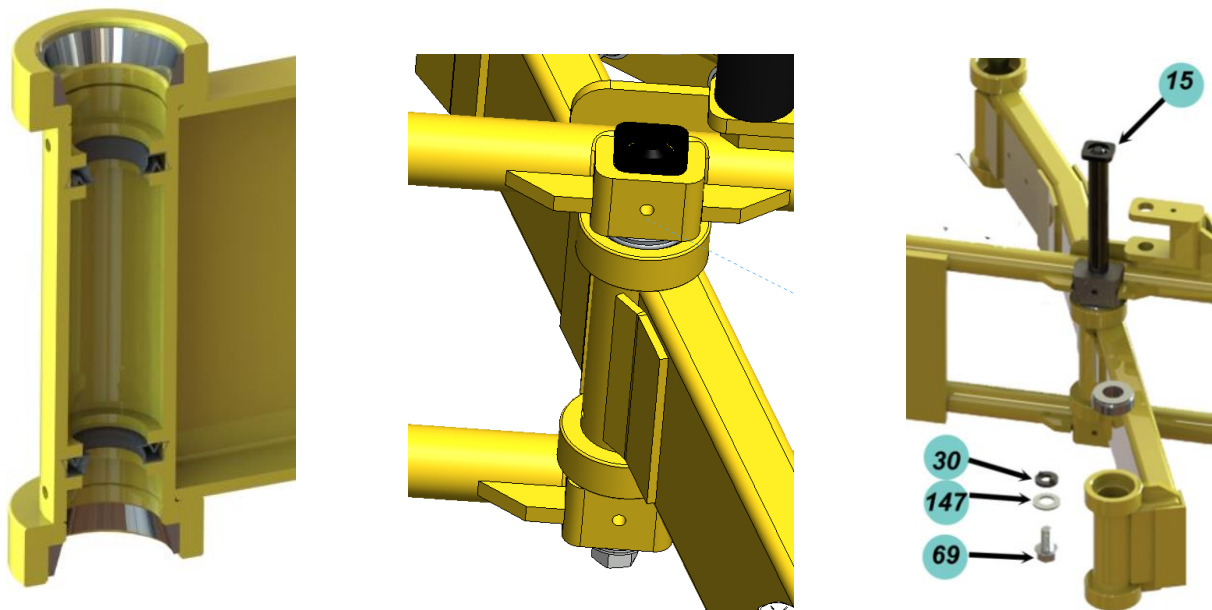

Insert the far end of the inside tube weldment (23) into the already installed slide bracket weldment (17), align holes and retain with pin (12) secure pin top and bottom with retainer disk (30) lock washer (147) and bolt (69). At this point half scissor is already assembled, by pulling or pushing the extremes with the hand, the unit should move, the mounting (18) can be impregnated with oil for the composite parts to better slide and facilitate movement.

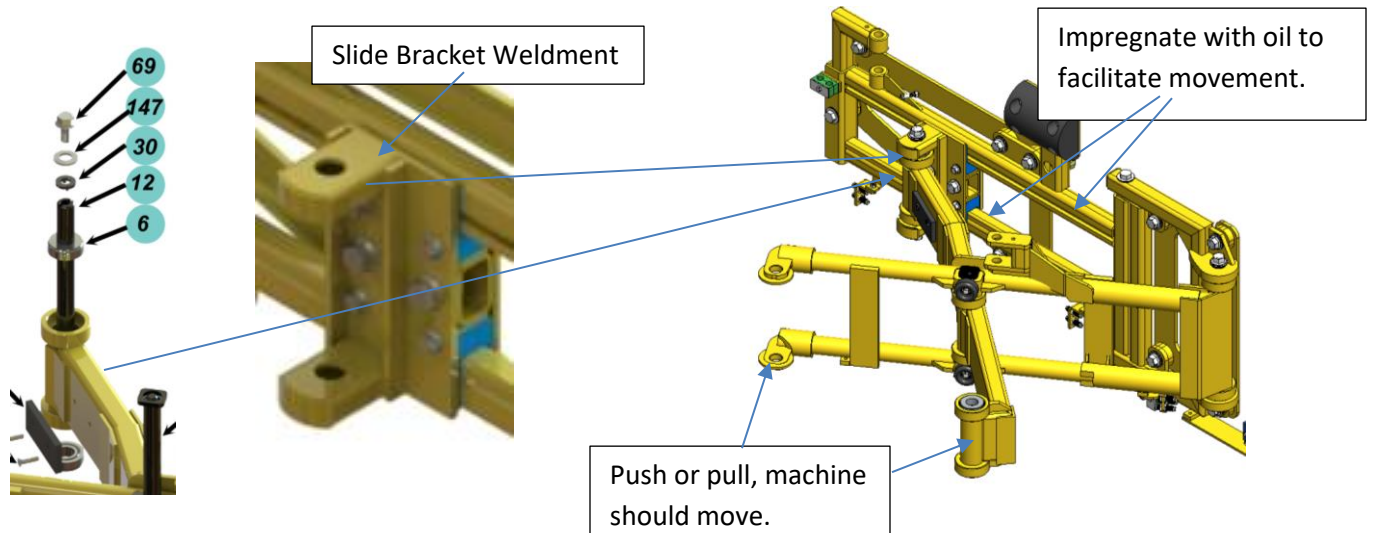

Attach bumper (8) to the inside tube weldment (23) with bolts (100). Install bumpers (1) to the main pivot weldment (35) with lock washer (148) and bolt (103).

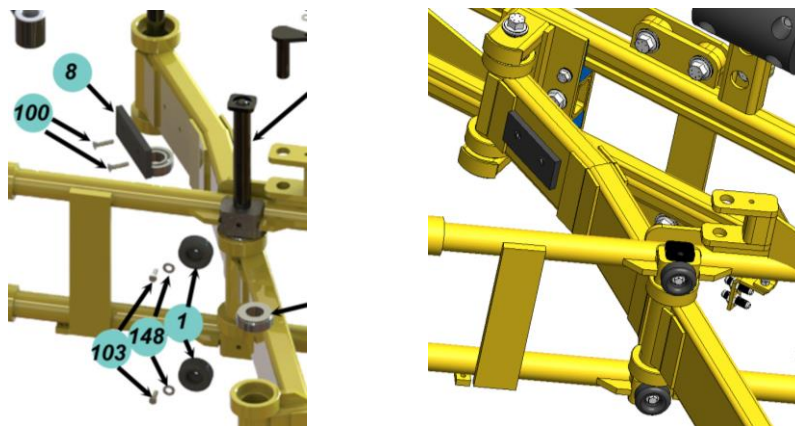

Insert bearing cases (6) and (21) and rubber seal (19) to front tube LH weldment (24). Insert front tube LH weldment (24) into correspondent space at main pivot weldment (35), align holes and insert pin (13) to retain, secure pin (13) top and bottom with retainer disk (30) lock washer (147) and bolt (69).

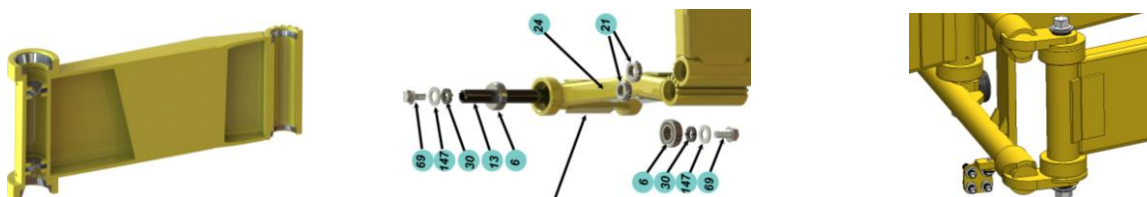

Insert bearing case (21) into front tube RH weldment (25), install bearings on inside tube weldment (23) and insert front tube RH weldment (25) into correspondent position at inside front tube weldment (23), retain with pin (11) and secure pin (11) bottom and top with retainer disk (30 lock washer (147) and bolt (69).

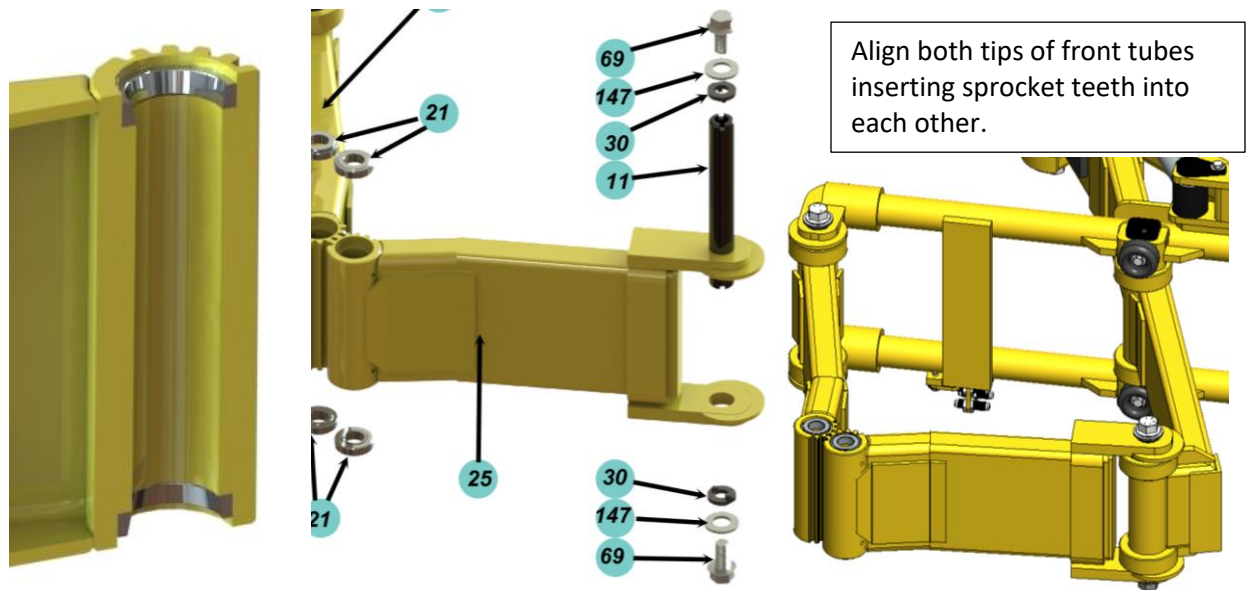

Align sprocket ends of both front tubes RH & LH (24) & (25) and put them together, the holes' distance should be 2-9/16", the sprocket teeth should interlock and holes must be in parallel line referenced to the back mounting. Insert the front mounting weldment (64) to tie together both front tubes (24) & (25) secure it with bolts (20) and nuts (102). The machine should still be loose and capable to move by hand if push or pull.

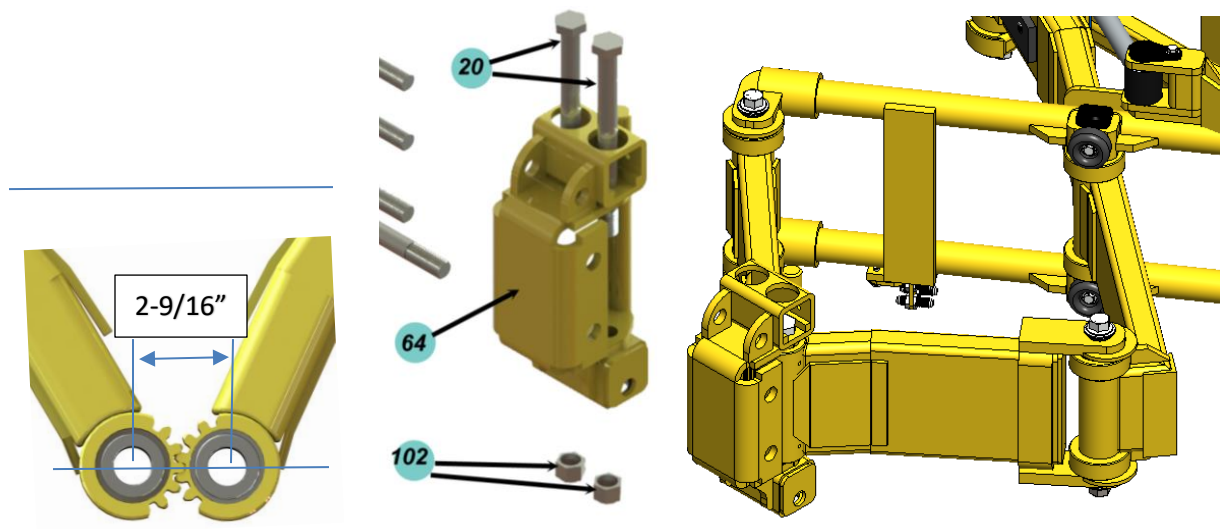

Install mounting bracket front weldment (63) on mounting bracket back weldment (64) and secure with bolts (142) and nuts (143). Insert hydraulic actuators (151) and secure them with plates (55) and (57) and clamping weldment (65) and secure them with lock washers (114), bolts (145) and bolt (117) and nut (102). Install upper rubber bumper (134) and secure with flat washers (116) and bolts (106).

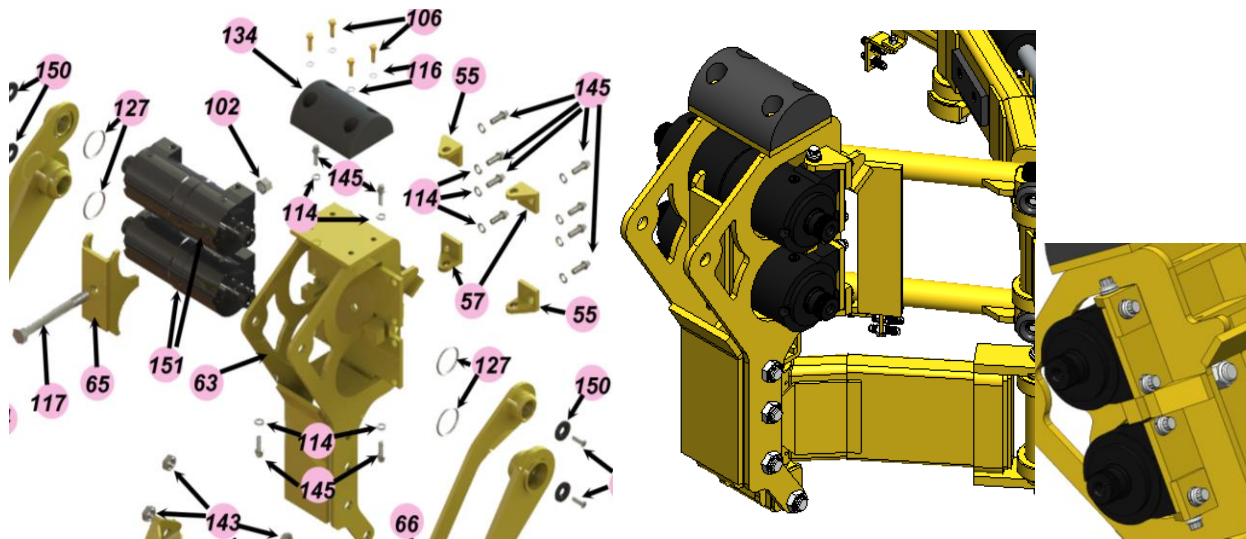

Insert the seal rings (127) into the ends of the actuators (151). Make sure both actuators (151) are all the way down and insert the driver arms (53) & (54). Insert them making sure the back surface of the drivers (53) & (54) is parallel to the back of mounting bracket front weldment (63). Insert the auxiliary driver arms (62) & (66) into the upper actuator (151), insert the auxiliary drivers (62) & (66) making sure there is a gap between upper drivers and lower drivers, both actuators are at the bottom end of their travel and the front surface of the auxiliary drivers (62) & (66) are almost parallel (1.29°) to the back of driver arms (53) & (54). Lock the drivers in place with retainer plate (150) and bolt (95).

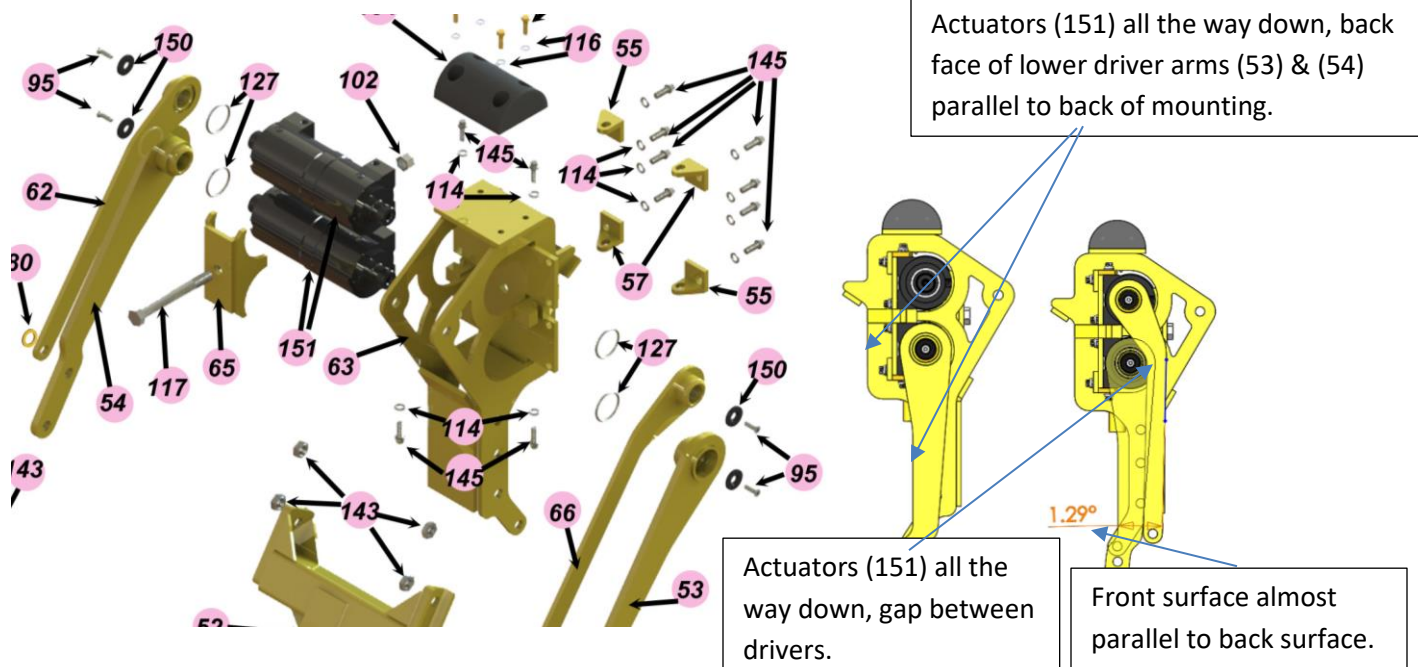

Insert bearing case (21) into center drive weldment (52). Attach center drive weldment (52) into lower driver arms (53 & 54) designated position. Secure with bolts (138) and nuts (143). Insert bearing cases (21) into slide weldment (61) and attach slide weldment (61) to the auxiliary drivers (62) & (66) designated position with the spacers (80) and bolts (144). Screw bolts (144) all the way in, do not fully tight insure free rotation and lock bolt by inserting roll pin (139), this roll pin (139) will keep the bolt from rotating and get loose or tight while the machine is moving.

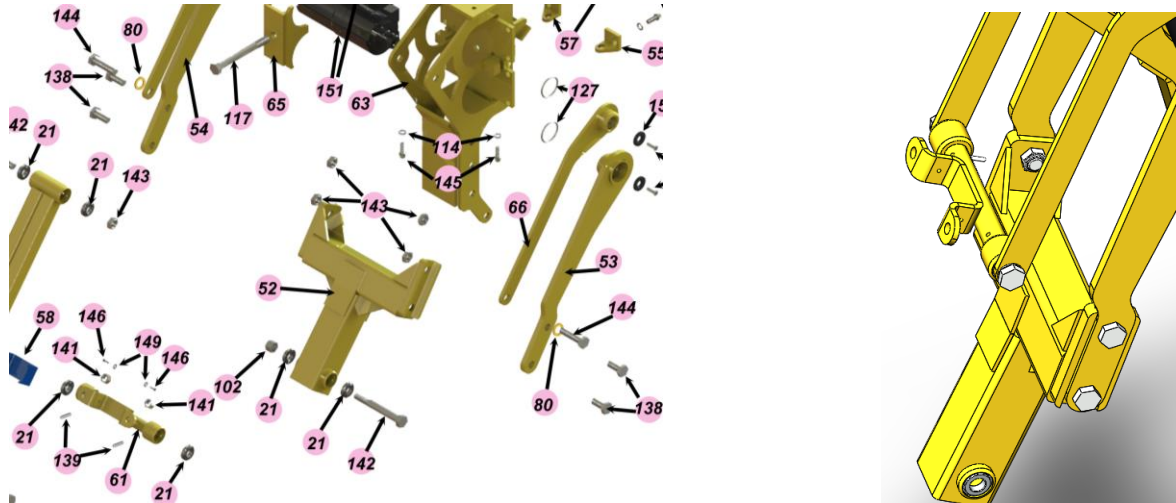

Insert bearing cases (21) into the idler tube weldment (56). Attach idler tube weldment (56) into mounting bracket front weldment (63) designated position and retain with bolt (142) and nut (143). Insert composite slide (58) into slide weldment (61) and retain with lock washer (149) and bolt (146). Trap the idler tube weldment (56) into composite slide (58) with top composite plate (60) cover plate (59) and secure the assembly with bolts (137) and nuts (141).

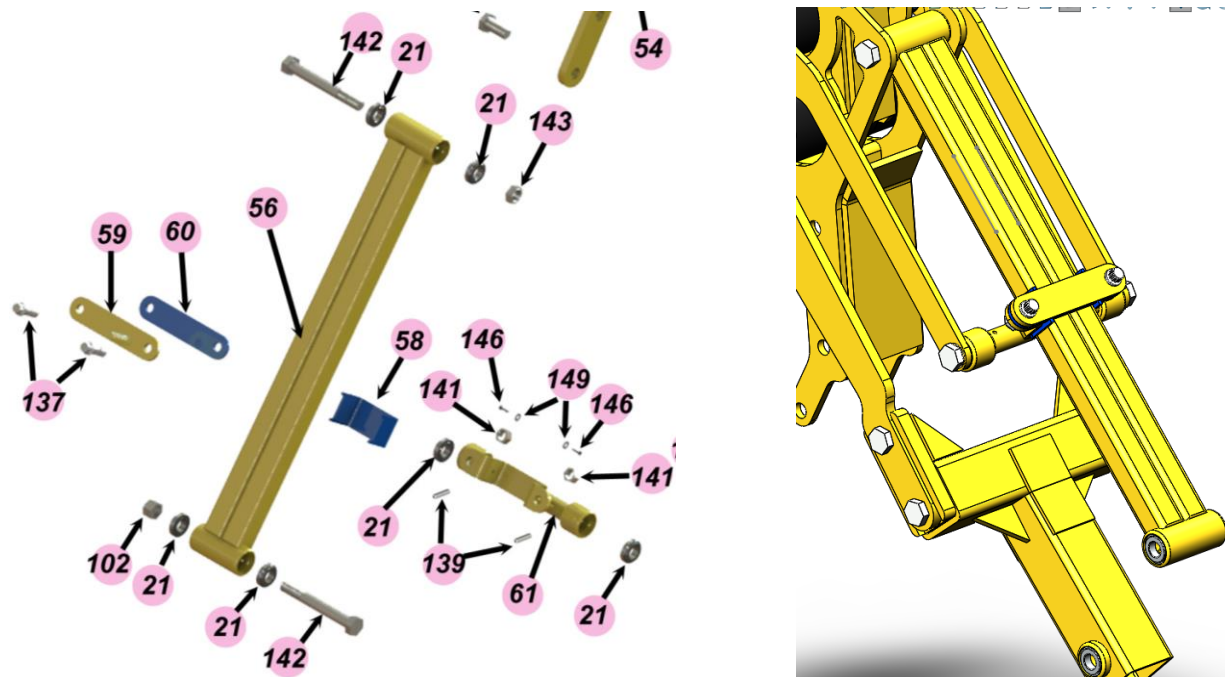

Attach grippers frame weld (76) with center drive weldment (52) and idler tube weldment (56) utilizing bolts (142) and nuts (102).

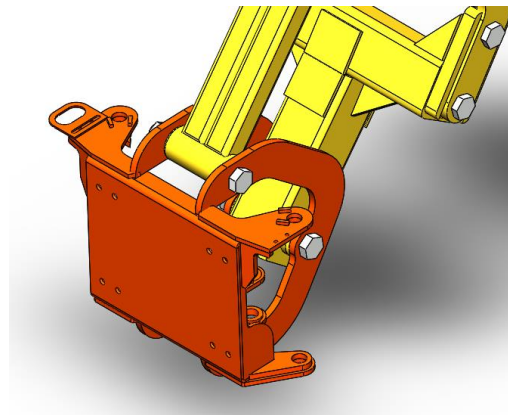
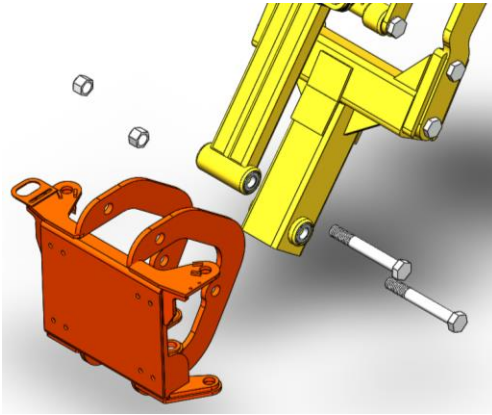

Attach front rubber pads (88) to grippers frame weld (76) with bolts (136) and nuts (104).

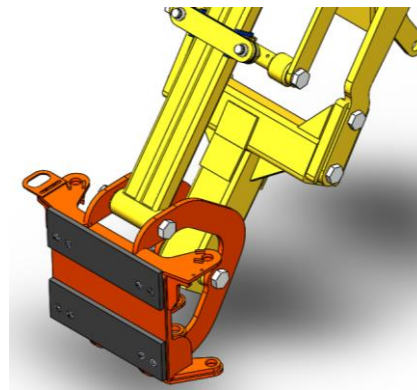
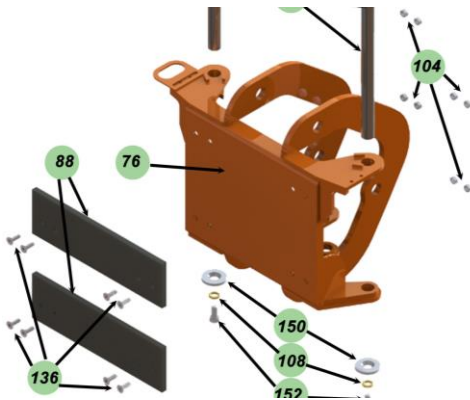

Insert bearing cases (21) into single gripper base weld (75) and double gripper base weld (82). Attach the single and double gripper base weld (75) (82) to grippers frame weld (76) into their correspondent side and retain them with pin (81) the fit must be close to perfect for the bearings to work good, if there is a gap fill it with spacer (80) or (101), lock the pin (81) with retainer (150).

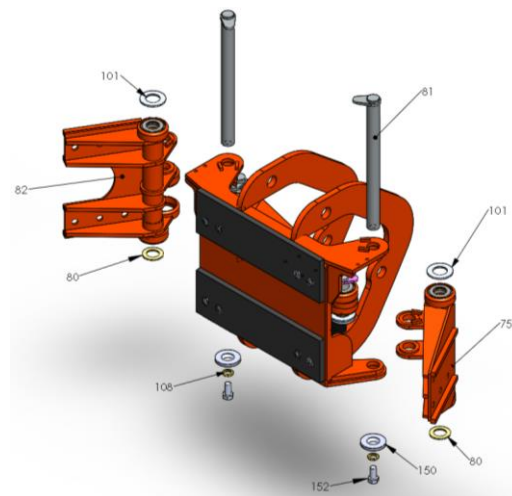
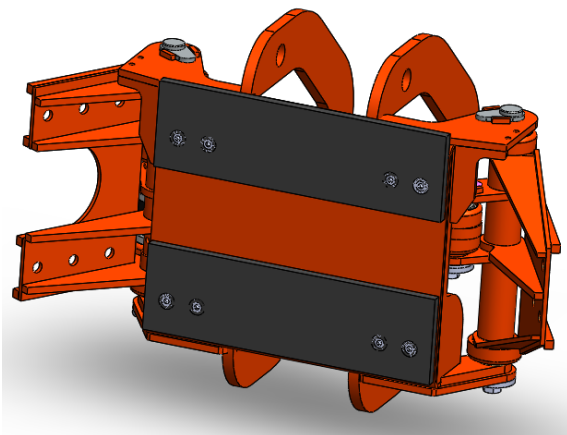

Insert bearing cases (21) into linkage weldment (79), attach hydraulic cylinder (73) at its base correspondent location on gripper frame weld (76) and retain with pin (77) lock the pin (77) with retainer (150) lock washer (108) and bolt (152). Insert linkage weldment (79) into correspondent location at the single and double gripper weldments (75) (82) engaging at the same time the rod side of the hydraulic cylinder (73) and the plastic spacers (67), retain with pins (77) and (78), the fit must be close to perfect for the bearing to work good, fill up any space with spacers (80) and/or (101), lock the pins (77) and (78) with retainer (150) lock washer (108) and bolt (152).

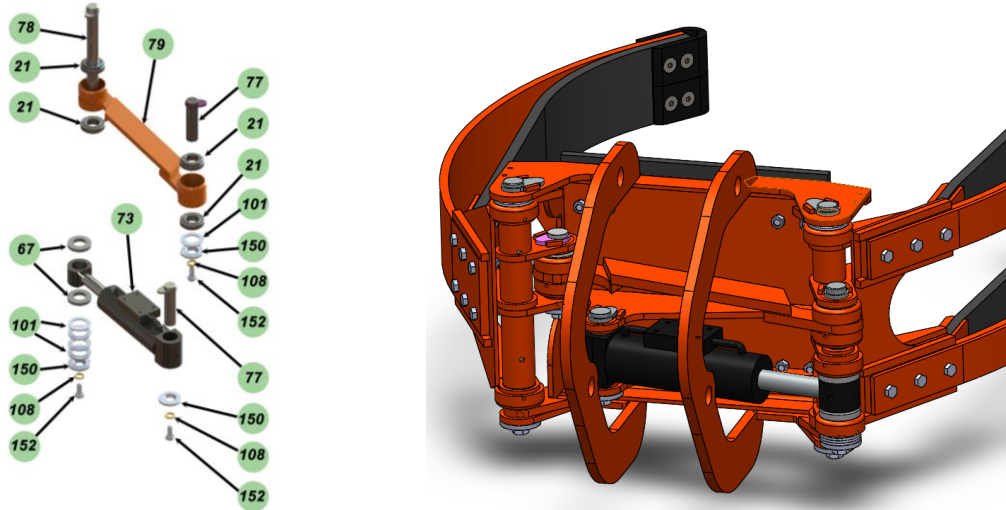

Attach rubber belts (74) and (87) to the bolt on plates (84) and (89) with top plastic plates (85) and (90) and secure with bolts (111) and nuts (104). Attach this assemblies together with the single and double gripper plates (86), (91) and (94) to the back of single and double gripper weldments (75) and (82) with bolts (99) and nuts (104). Attach the other side of belt (74) and (87) to their correspondent side at the single and double gripper plates (86) and (94) with the plastic tip (88), bolts (140) and nuts (104). Insert the center brackets (92) at the double gripper and attach them with spacer plate (93) utilizing bolts (99) and nuts (104). Install all the grease zerks (153) and grease the entire unit prior to hydraulically move for first time.

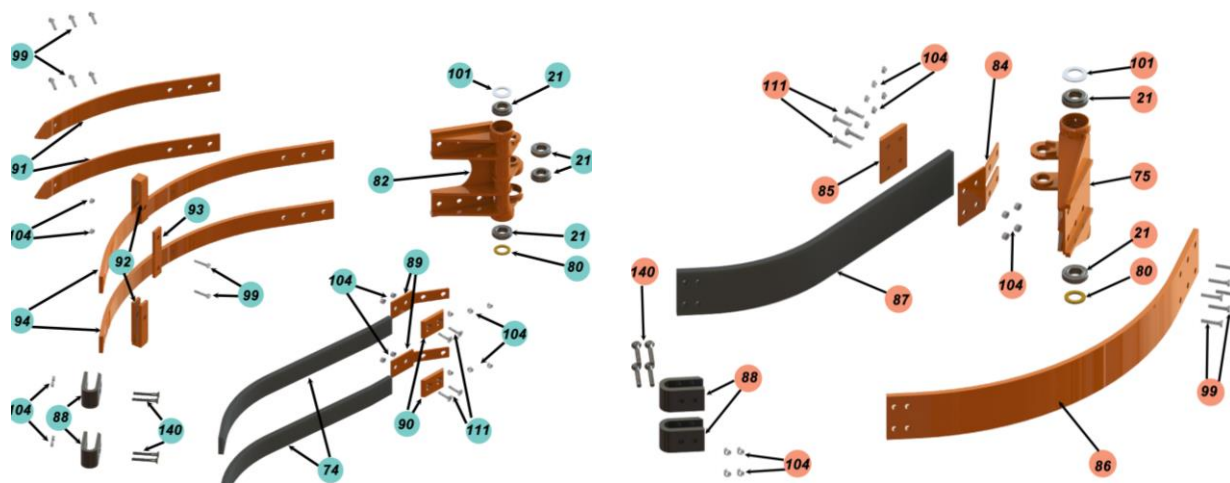

Hydraulic Oil

The most important component of any hydraulic system is the oil. Perkins cart lifters use standard seal materials and should therefore be compatible to most grades of hydraulic oils, operating in typical weather conditions for most of North America. However, the condition of the oil is an important consideration that should not be overlooked.

Hydraulic oil may be dirty, contaminated, lost its viscosity, burned up, or have too high a concentration of absorbed water and/or air. While these things are unlikely to cause an immediate performance issue with your cart lifter, these issues can lead to premature wear and tear in the longer term.

Perkins would like to take this opportunity to remind you to check the quality of your hydraulic oil periodically and make sure it meets your standards. Oil that is maintained in good condition will help your equipment last longer.

Non-Perkins Control Valves

Some customers with new trucks may choose to use hydraulic control valves provided by the OEM. If the GPM and pressure settings used match the specifications required, then the lifter should operate fine. Perkins equipment do not require special Perkins valves to operate.

In other cases, a Perkins equipment may be replacing a competitive lifter for which control valves are already installed. Again, Perkins equipment should work just fine with competitive equipment, if the GPM and pressure settings are adjusted within the specified ranges.

Lifter Speed

The cycle time of the lifter is very important for safe operation. Perkins suggests a complete cycle time of 10-12 seconds (FULL CYCLE) or slower. Faster cycle times may be dangerous. Running a lifter too fast can damage the equipment, resulting in damage and/or injury.

The speed of the cart lifter is determined by the rate of oil (GPM) going to the unit. The PAS2.5 lifters will require approximately 10-12 GPM to meet this speed. A gauge is recommended but not needed to determine proper lifter speed. Counting the cycle time using a stop watch is adequate to determine proper flow rate. **Running the equipment too fast will void the warranty.**

Weight Capacity

The maximum amount of weight that can be lifted is limited by the pressure relief valve at the pump, or at the valves or both. The settings must be determined with a pressure gauge. The PAS2.5 requires 2,100 psi to lift a 400 lbs of load. Place a pressure gauge after the control valves and run one function until it stops, continue activating the control valve and note the pressure on the gauge. Adjust the relief valve per the manufacturer's instructions.



Hydraulic Source

First, we need to identify or determine the hydraulic source. There are different ways of sourcing pressurized hydraulic oil:

- 1- Tap a divider valve into an existent truck's hydraulic system. This type is the most common way of doing it on regular hydraulic lifters, because they required low amount of flow (2-8 GPM). However, it could also be use in automated cases (10-20GPM) if the reducing of speed of the packer system is not an issue. Normally the truck's packing mechanism will work full speed when the automated lifter is not in motion, meaning that, during collection the packing speed is low and full speed is achieved between houses (points of collection). Please see the following instructions to install this option.

Flow Diverter Installation

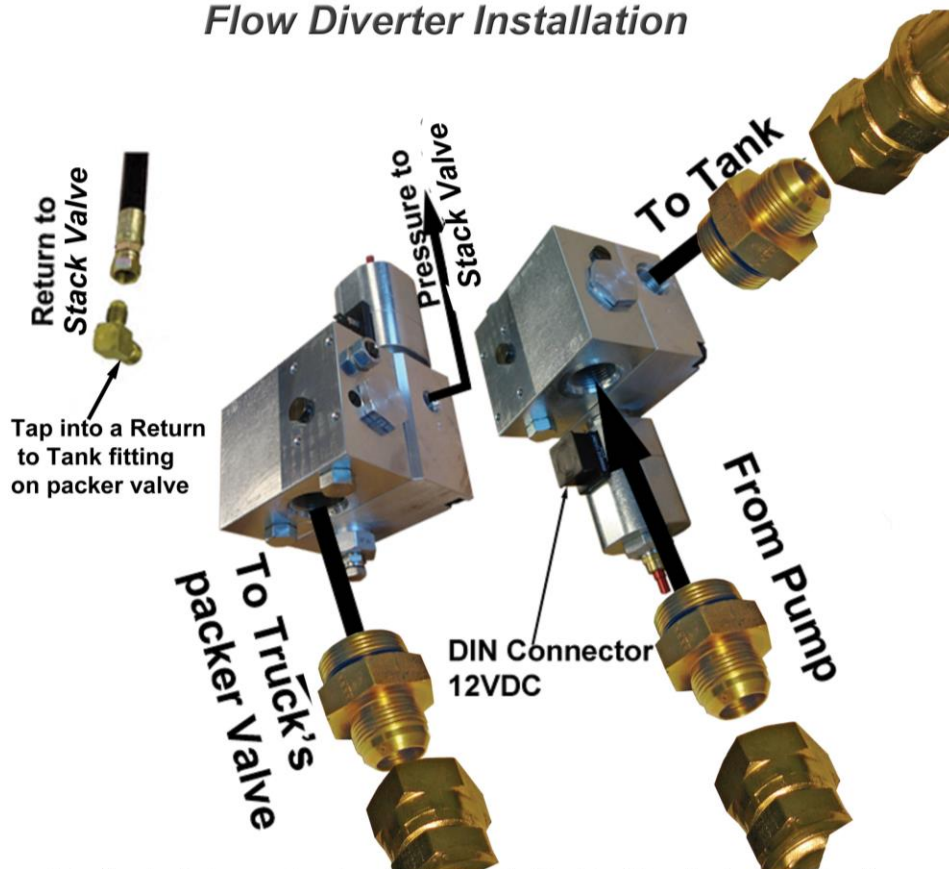

Note: Trucks that are equipped as semi-automated (residential) collectors may already come with a flow diverter. Also, if your truck had another automated from a previous installation, the flow diverter should already be installed.

As long as the exiting plumbing can be adjusted to deliver 10 to 12 gpm to the automated, the existing plumbing will work for the Perkins PAS2.5 system.

If your truck does not come equipped, it will be necessary to install the flow diverter valve shown above. The valve should be placed so that the line feeding the packer valve will now feed into the diverter. The diverter will then feed into the packer. The diverter allows the packer to continue to function much slower than normal, while siphoning off 10-12 gpm for PAS2.5 to function.

The solenoid shown allows the 10-12 GPM to flow only when the joystick is activated, which keeps heat low and normal speed to the packer when the PAS2.5 is not in use.



Hydraulic Installation (Continuation)

Hydraulic Source (continuation)

2- The most common option for automation is the use of a secondary pump. This is, to replace the existent hydraulic pump with dual (tandem) pump, two pumps in one. Knowing that the automated will need 10-12 GPM at idle and with 2100 PSI, we will need the information of the existing pump to match a tandem pump for the two systems. Normally with the serial and model number of the existent pump will be enough to find a match, but occasionally the truck model and serial number will also be necessary. The pump should match the exact mounting path as the existent single pump. Once the Tandem pump has been installed, this will suck the oil out of the reservoir for the two pumps at once. The pressure hose for the system already in place should also fit perfectly on the pressure outlet port (main port) for the primary pump (existent hydraulic system). We will need to add a second pressure hose from the pressure outlet of the secondary pump (Secondary port for the automated lifter) to the pressure port of bank valve assembly for the automated unit and a return hose from the return port of the bank valve assembly for the automated lifter to the filter of the hydraulic reservoir located at the tank entrance of the returning oil.

Replace with a Tandem Pump



Existing Single Pump

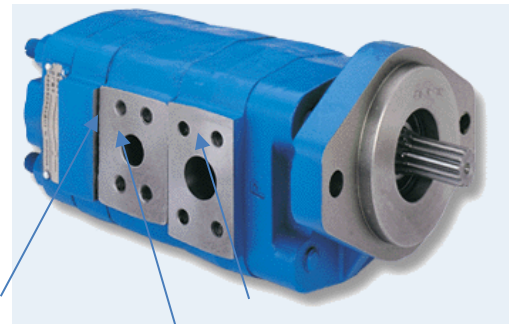

Secondary Port

Main Port

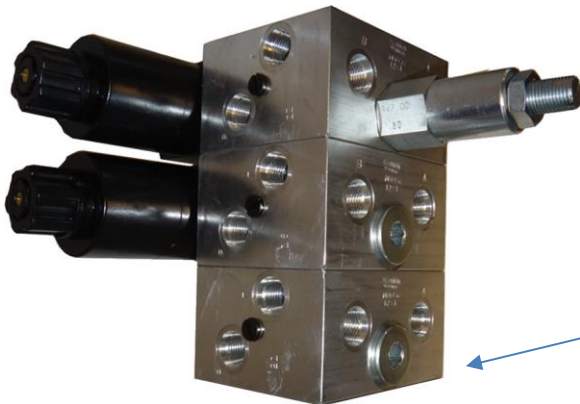

Secondary port of the tandem pump, to the pressure port of the bank valve assembly.



Hydraulic Installation (Continuation)

Hydraulic Source (continuation)

- 3- In special occasions a secondary pump can be installed separated from the main pump. There are some trucks that have a front mount pump, and a tandem pump is not an option mainly because of the spacing. In these cases, a secondary pump can be installed directly into the transmission, this will require not only the pump but also the PTO to transfer movement from transmission to pump. Will require also for the transmission to be equipped for this option, normally will have a capped notch at one or both sides of the transmission, if this capped notch is not visible then this option is not available, also, with model and serial number of the transmission contact manufacturer to find if this option is available.

Install the PTO in the space available, if any questions Perkins will be glad to help but is recommended for the installer to call directly to the service line of the PTO and/or the transmission manufacturers. Install the pump on the PTO. With this option, we will need to do more modifications. We need to install a hose from the inlet port of the pump to suck oil out of the existent hydraulic reservoir or install another reservoir (if installing another reservoir, a filtering system will also be need it). Run a pressure hose from the outlet port of pump to the pressure port of the bank valve assembly for the automated lifter and the return hose from the return port of the bank valve assembly to the reservoir tank just before the filter (this way the oil coming from the automated gets filtered). Install the rest of the equipment provided with PTO per the instructions (normally included with the PTO) to make the system functional. Prior to the first activation revised the installation one or two times for proper installation. If any questions Perkins will be glad to help but is recommended for the installer to call directly to the service line of the PTO manufacturer.

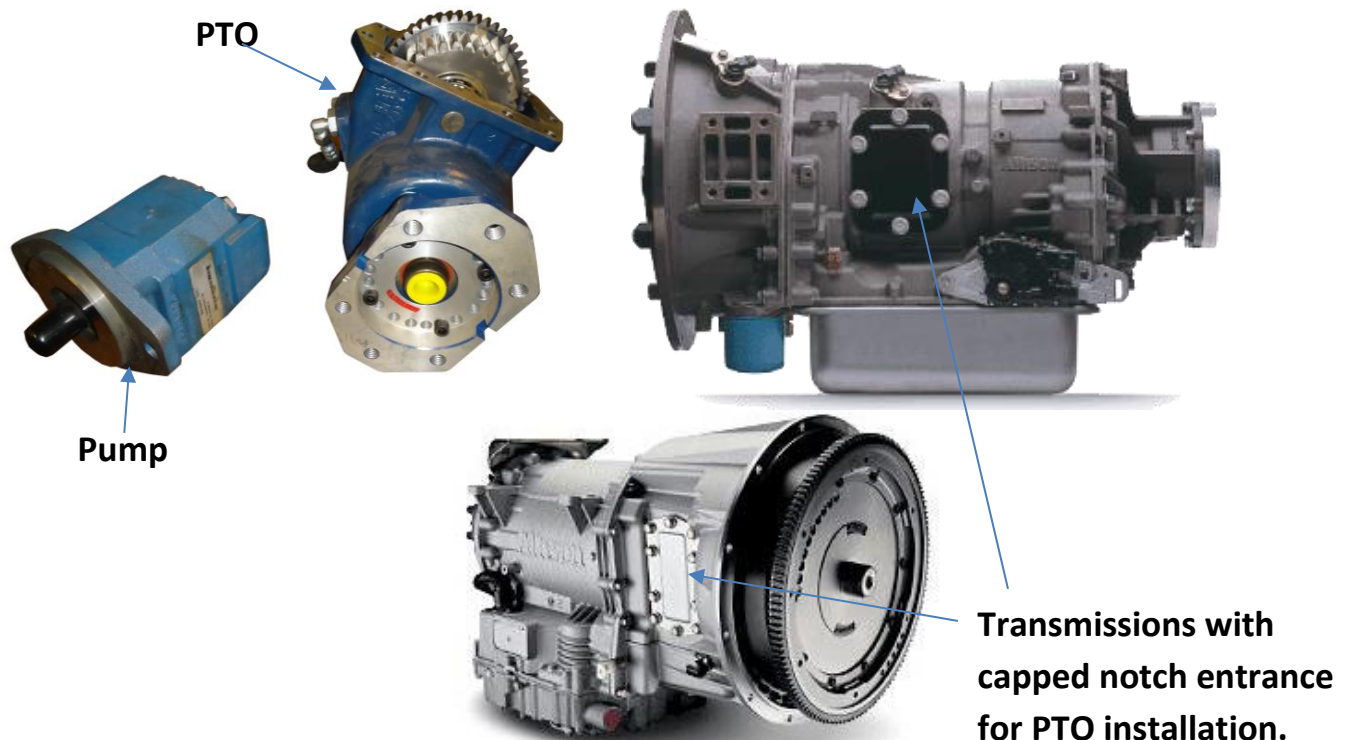

Hydraulic Valves to Control

Hydraulic Stack Valves

As part of the machine we have 3 hydraulic devices to control. See the hydraulic schematic. The valve assembly has everything incorporated with P.O. check valves to keep the machine from moving itself when is not supposed to move and adjustable flow valves to restrict oil on those operations demanding less oil than the supplied (especially the grippers). Install this valve within accessible place for adjusting and maintenance purposes but well protected from external objects, debris, and waste material so can be maintained as clean as possible. The pressure adjusting screw is over one section of the valve and will be set to 2100 PSI. However, during installation, we recommend to use a pressure gage at the pressure line to make sure this is set correctly. If adjustment is need it, loose the nut and screw the bolt in to raise the pressure or out to lower the pressure, before doing any adjustment to this setting you must do two things, to measure and be sure system that is below 2100 PSI and to call Perkins service department for proper adjustment instructions, otherwise warranty will be null. See picture below. Normally the adjustable flow valves are also already set, however if adjusting is need it, they are attached to the sections at the A & B ports. Screw in to lower flow (speed) and out to raise flow (speed). This flow adjusting is only possible on the two sections with smaller valves (grippers control valve and Dump & down) if speed is within the specifications with the restrictors all the way open, we recommend to completely remove from the circuit. With the grippers valve function, there is a pressure relief connected between ports. This is an independent pressure setting that works only one way, normally set to 1200 PSI, to avoid the grippers crushing plastic carts. If the grippers closing does not work, generally is because this relief valve is set too low and needs to be adjusted higher. If the grippers are crushing cart will need to be adjusted lower. See picture.

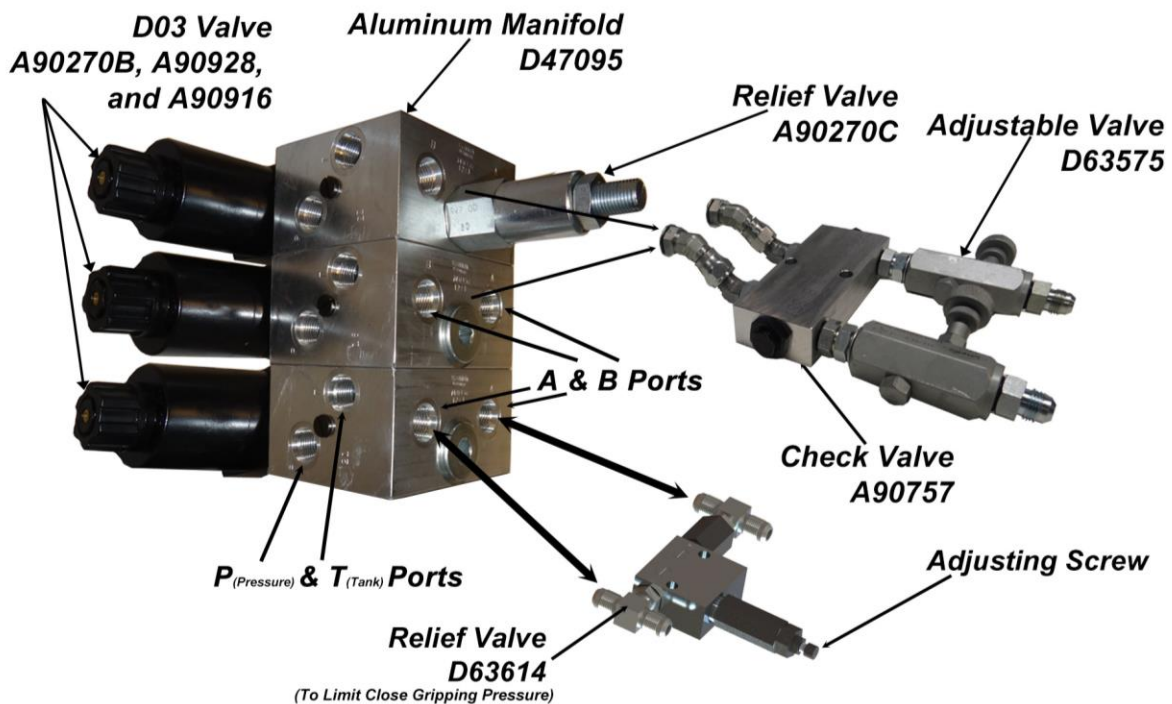

NOTICE ON THE POSITION OF THE D03 DIRECTIONAL CONTROL VALVE STACK

The control valve stack must be installed in a way that the d03 spool is horizontal at all times. Inside the valve is a spool with springs. The springs self-center the spool when the power is disengaged. When positioned horizontally, the spool self-centers normally. When incorrectly positioned vertically, the springs must work harder to return the spool to center, which may lead to jamming and malfunctions.

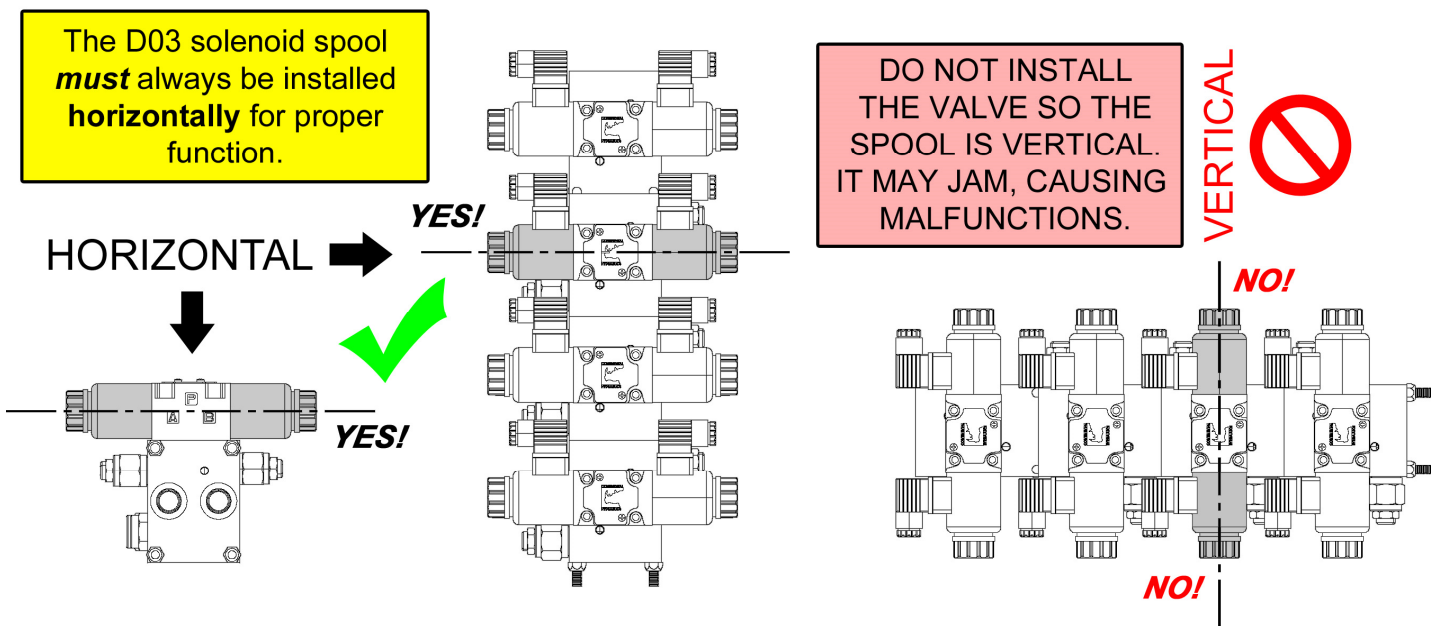

Please orientate the valve properly during your installation process so malfunctions do not occur.

If the spool does become jammed, it can be freed by manually sticking a screwdriver into the slot at the end of the spool and giving a small push to un-stick the spool.



Hydraulic Schematic & Components List

Item	Qty	Part#	Description
1	3	D47095	station D03 aluminum manifold w/SAE ports
2	1	A90270C	100-4000 PSI adjustable Relief, C10-2
3	1	A90916	Prop. Valve A, B to T, 12VDC coils, D03
4	3	A90916-2	10-24 x 2-1/2" long SHCS bolt kit
5	1	A90928	Prop. Valve Closed Center, 12VDC coils, D03
6	1	A90270B	Solenoid Valve, 12 VDC coils, D03
7	1	A90809	Normally Open Popet Valve 12 VDC
8	3	A90757	In-Line Dual Pilot Operated Check Valve
9	1	D63615	Cylinder Dual Pilot Operated Check Valve
10	5	D63575P	In-Line Adjustable Flow Control
11	1	D63614	Pressure Relief

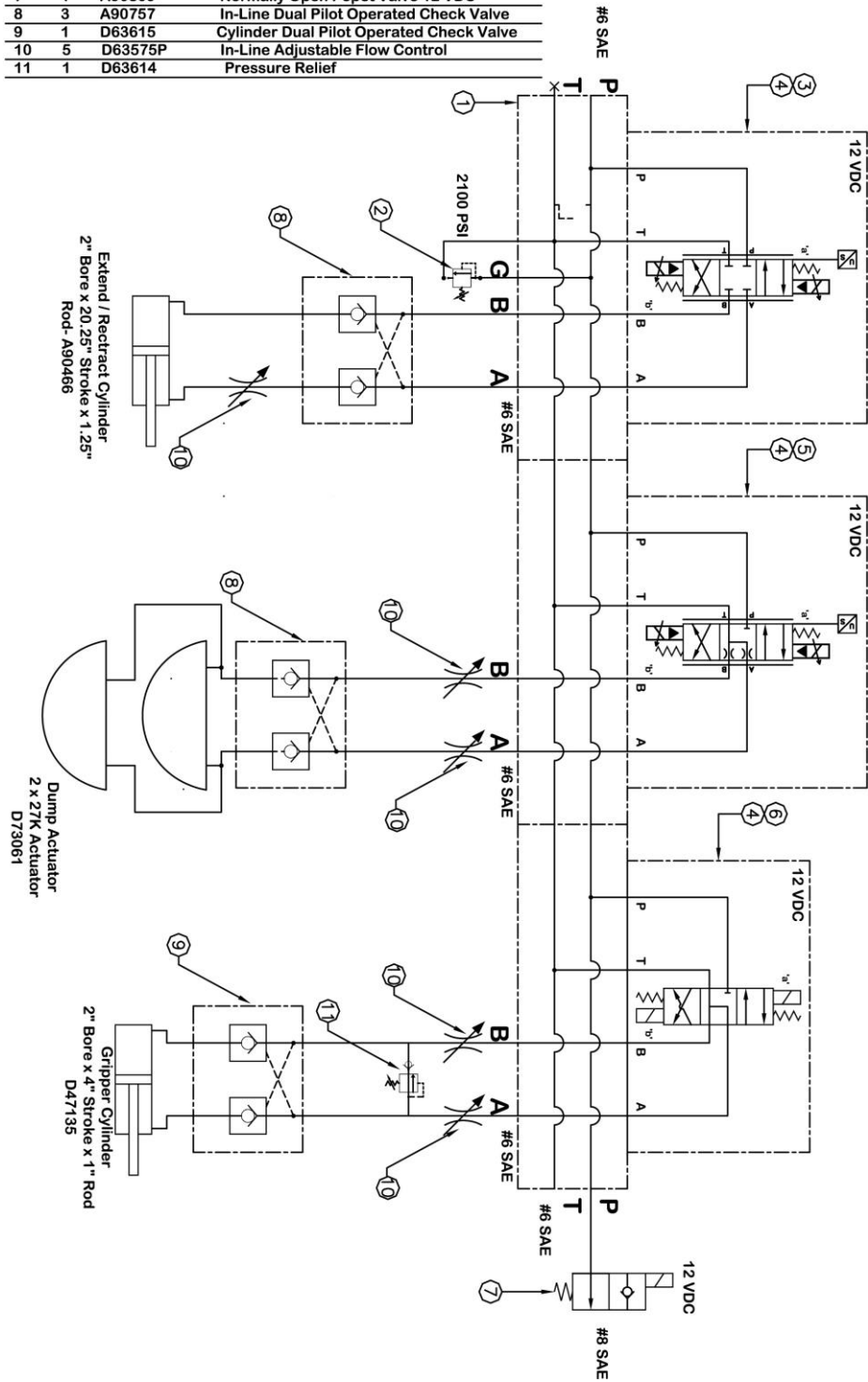

Single Box Schematic

A91166 Electric Control Box Assembly

With extra relay & sensor for cushioning and indicator light

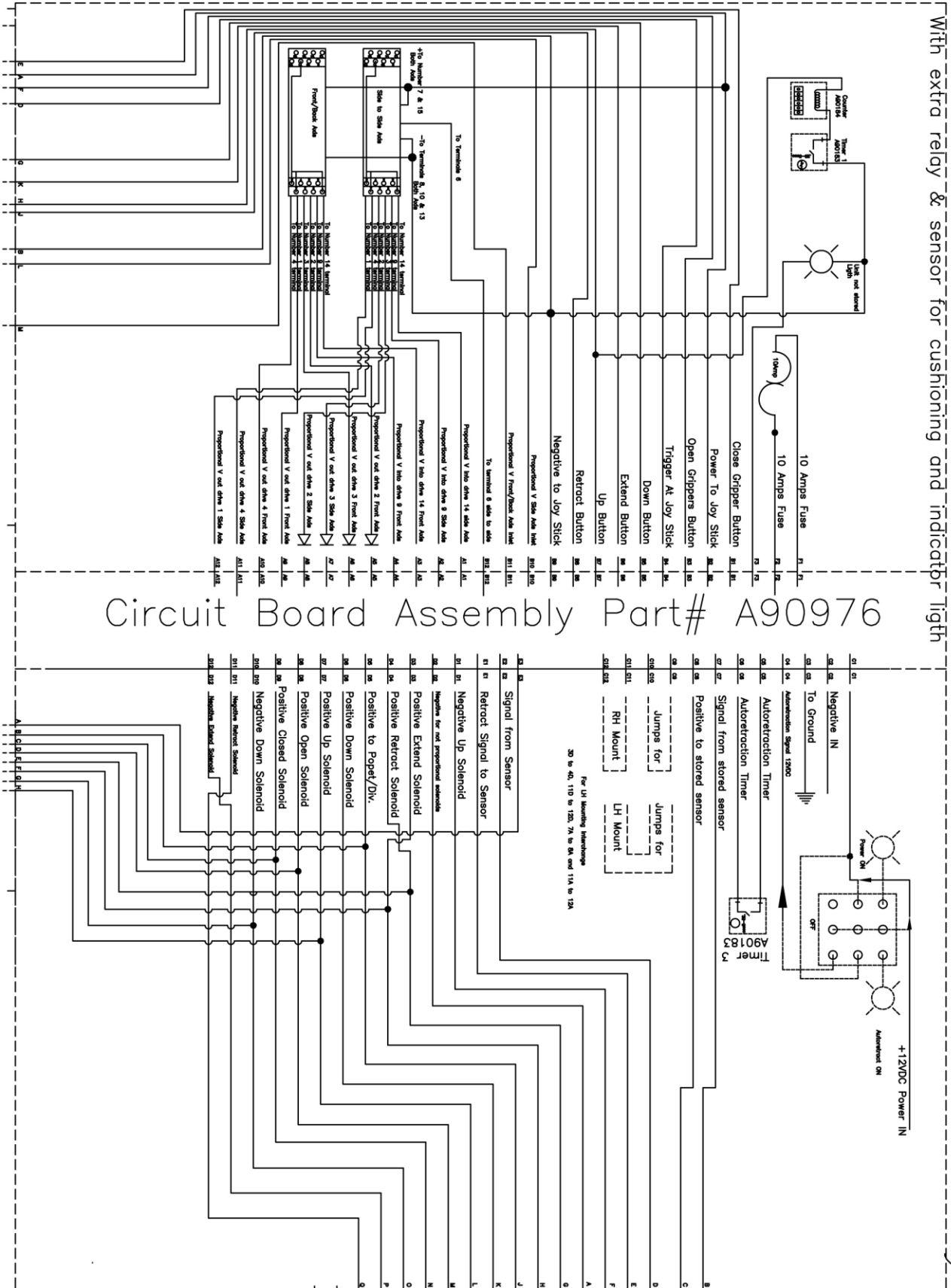

Joystick and Harness Schematic

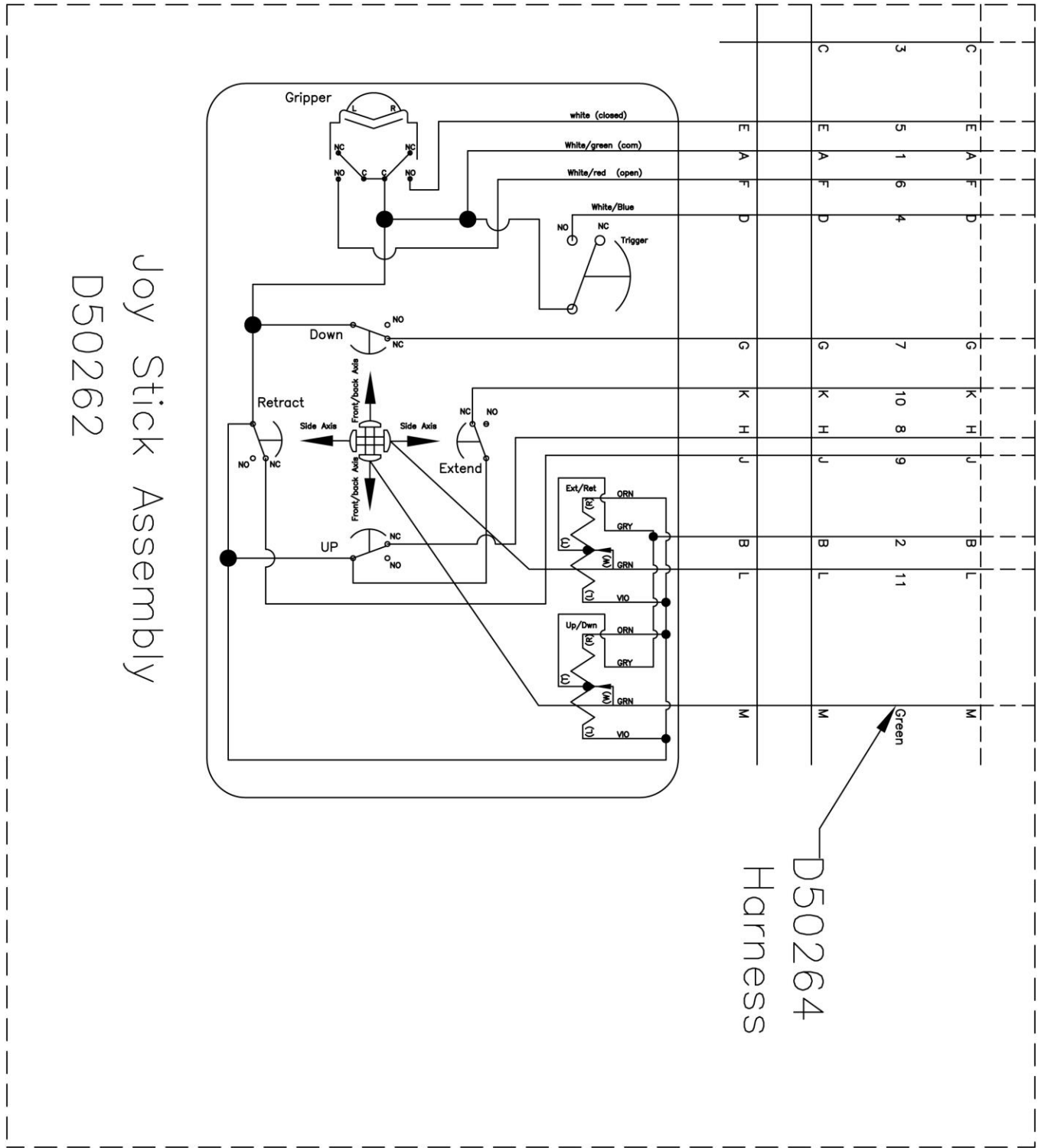

Joy Stick Assembly
D50262

D50264
Harness



Push Buttons Schematic

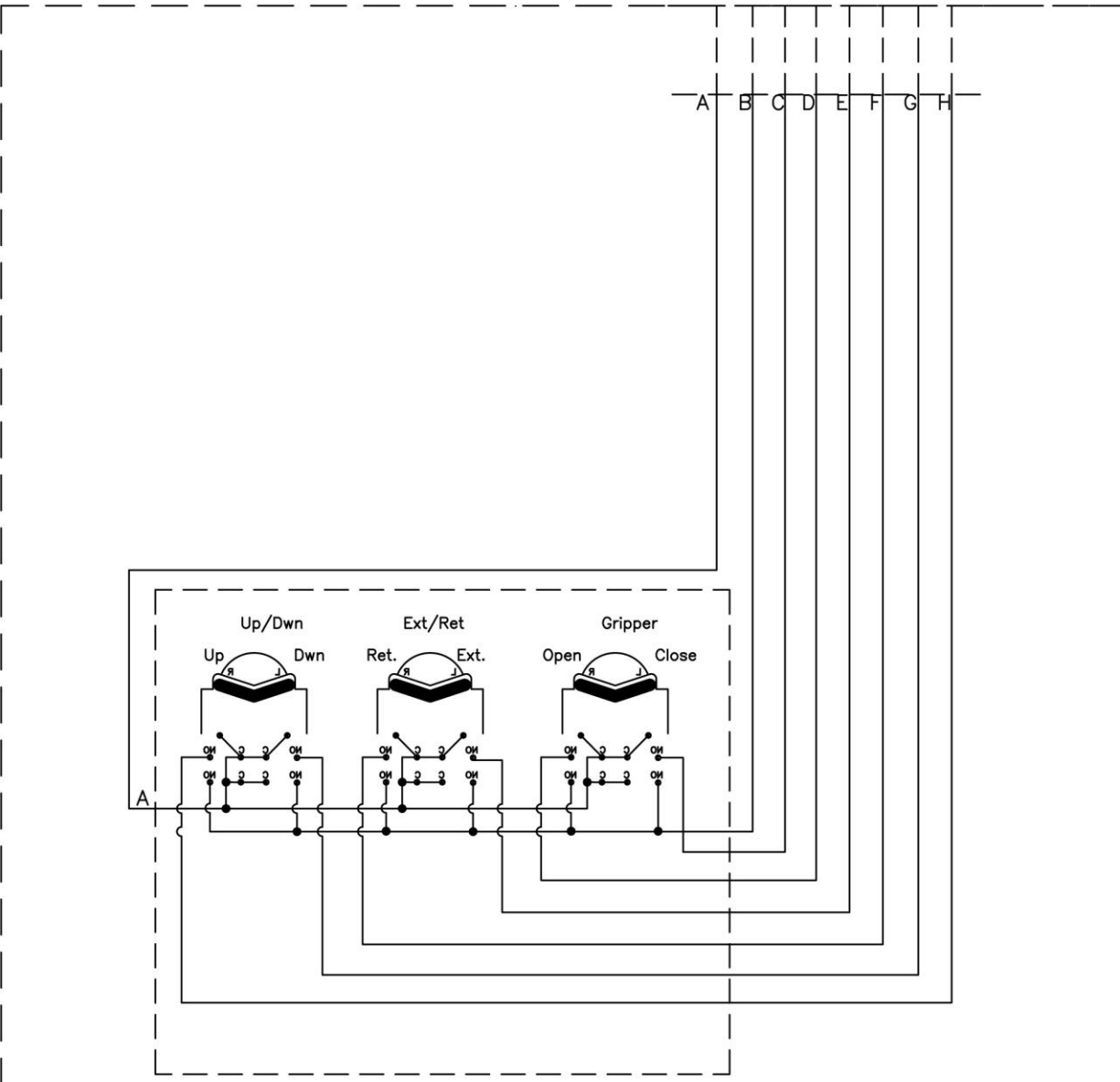

Push Button & Harness D50215



Main & Plugs Harnesses Schematic

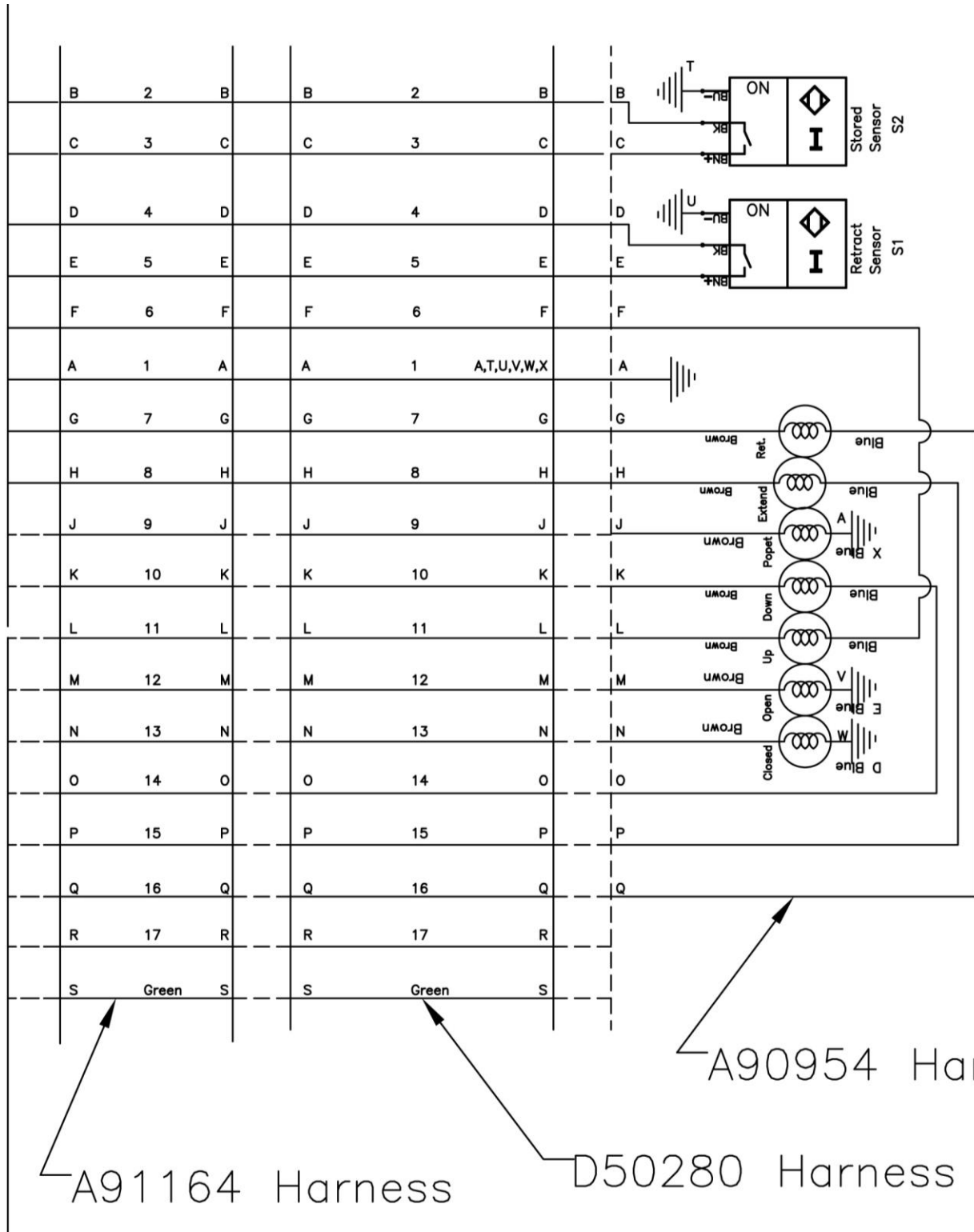

Electrical Installation

A91196- Electrical Box Assembly
 Install inside of the cabin protected from outside weather. Normally at back of operator. Better if front panel is visible and accessible for future servicing.

1 Pc- D50262- Joy Stick
 Install Driver side or passenger side comfortable position for operator to control. Use D50274 or A90879.

1 Pcs- D50264- Harness Joy stick to Box. Connect to joy stick, fish through and connect to electrical box.

Connect this to a 12VDC 10 Amps power source.

OR

D50274- Use when attached higher than floor.

A90879- Use when attached to the chassis's floor.

Fish through and connect to electrical box.

1 Pc- A91164- Harness box to chassis.
 Drill 1.75 OD holes on chassis to the exterior, hidden, not accessible, hard to get to and/or well protected, to avoid any damage with people moving in and out. Insert ends on the holes, secure with washer and nuts, fish through the cabin to the electrical box and connect to it.

1 Pc- D50215- Push Button Station.
 Install a hanger for this station inside of the cabin, normally under neat passenger seat, close to the door. For use as a backup, when driver is outside close to the machine or maintenance purposes. Individual operations only, no conjunction movements and no proportional control.

A90954- Plugs & Sensors Harness.
 Connect to its correspondent match and connect to the individual functions as marked.

Valve Stack Assembly.

A90298- Bracket.
 Weld it close enough to reach bank valve.

- D50280- Harness from Chassis to valve Bank.
 Connect to the correspondent connector at the chassis and fish through the outside chassis and body to the valve bank. Tide only to fix parts and free of friction against other components



Electrical Harnesses, Sensors and Controls

Electrical Components

Optionally the machine can be sold complete with the necessary components to make it functional. The electrical components are: Joystick assembly (with enclosure and bracket to mount in the cabin), harnesses and sensors. See exploded view at the previous page. The electrical system has been designed to be stand-alone, meaning that, not inter-action between this system and any other electrical in the truck. This makes it easy to install or remove without affecting any other functions within the truck. Perhaps the only instruction involving the truck electrical system is: to provide a **12VDC 10Amps** power source to power the automated electrical system.

Installation of the components

Once the control bank valve has been already installed as described in page 15. Weld the provided bracket (A90298) for the DIN connectors harness, install it close to the bank valve calculating that DIN connectors need to reach the valves the way they are marked.

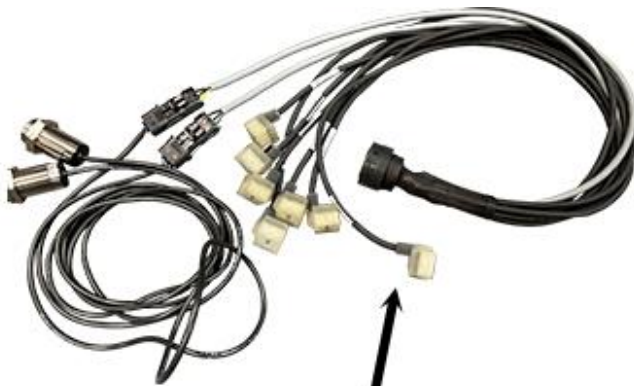

**A90954-
Plugs & Sensors Harness.**
*Connect to its correspondent
match and connect to the
individual functions as marked.*



A90298- Bracket.
*Weld it close enough
to reach valve stack.*

Valve Stack Assembly.

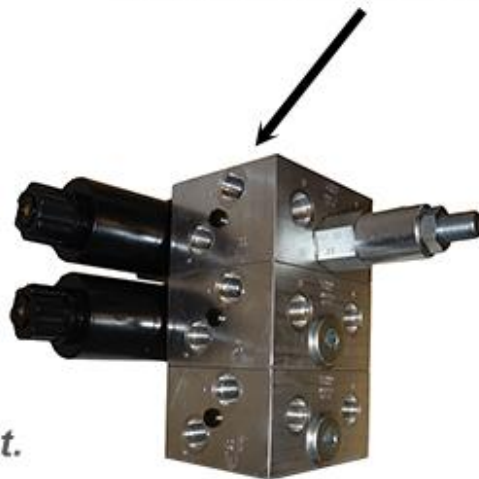

Determine the location of the Joystick, this should be close to from where the operator is going to be seated performing the collection in a comfortable position as much is possible. The performance of the collection has a lot to do with the way the operator is comfortable or not. If the joystick is going to be mounted to the floor, please order, and use the mounting bracket A90879. Or if is going to be mounted to on top of something (e.g., dash top) please order and use D50274. Utilizing the adequate bracket mark the hole's location and drill to mount the joystick, secure it with bolts and nuts (not provided). Adjust the appropriated height angle for the designated operator.

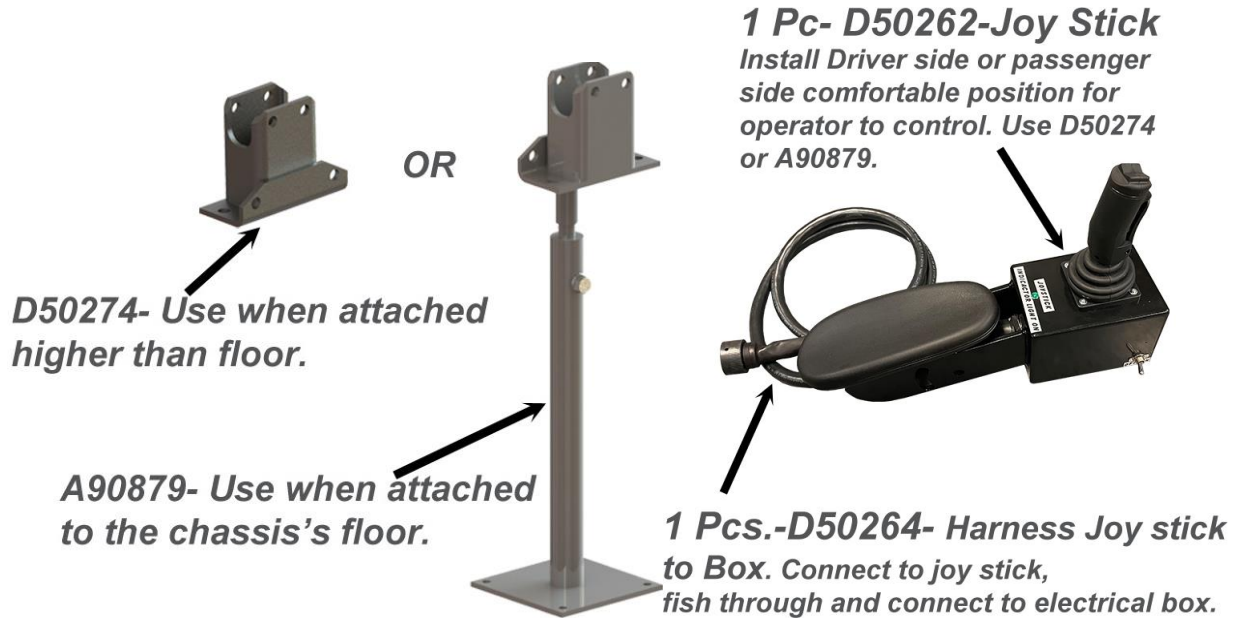

Locate a place where to install the electrical box (A91166), needs to be inside of the cab or any other place protected from the outside weather (water). Will also needs to be within the reach of the harnesses of the components that will be connected to. The joystick will connect to the box with harness D50264 which is 10ft. length, the push buttons (D50215) will connect to the box with a wire of 10ft length and from the box to the wall going out to the rear, goes the harness A91164 which is 6 ft. long.



Harness to wall going outside will connect at the contrary side, to its marked position.

Harnesses from Joy Stick and push buttons station, will connect at this side to its marked position.



Install the push button station (D50215), better if is installed under the seat at the side to where the machine is installed, the purpose is to have it as back up, for the operator to use when is outside the truck with visual contact of the machine and for maintenance purposes. These station controls individual functions, one push button per hydraulic devise movement no combined functions and no proportional movements. Operator needs to have direct visual contact of the unit when activating these switches.

1Pc- D50215- Push Button Station.

Install this station

inside of the cabin, normally under neat passenger seat, close to the door.

For use as a backup, when driver is outside close to the machine or maintenance purposes.

Individual operations only, no conjunction movements and no proportional control.



Connect to the box the harnesses coming from the joystick and push button station, all the harnesses will need to be properly routed and tied to fix parts (no movement at any time) and friction free. Hidden or protected from contact or step on people as they go in and out of the chassis.

Determine where is the best place to drill the cabin two 1-3/4" OD holes, where the inside harness (D50261) will connect. Will need to be a spot where there is no electrical, air or any other lines and hidden from traffic of people going in and out of the cabin.

Be careful not to, cut electrical, air or other lines that might be present in the area.



A91164

Drill two 1-3/4" OD holes in the chassis wall and insert harnesses end connectors, add washers and nuts and tight.



Look for a power source within the truck that turns ON with the key and is off when the truck is off. This power source needs to be 12VDC and 10Amps, the system could malfunction if the voltage drops lower than 9.5VDC. Connect the three-strand wire part of the harness D50261, white positive, black negative and ground the green. The box has a 10amps fuse integrated, then no need to install any other fuse.

A91166- Electrical Box Assembly

Install inside of the cabin protected from outside weather. Normally at back of operator. Better if front panel is visual and accessible for future servicing.

Connect this to a 12VDC 10 Amps power source.

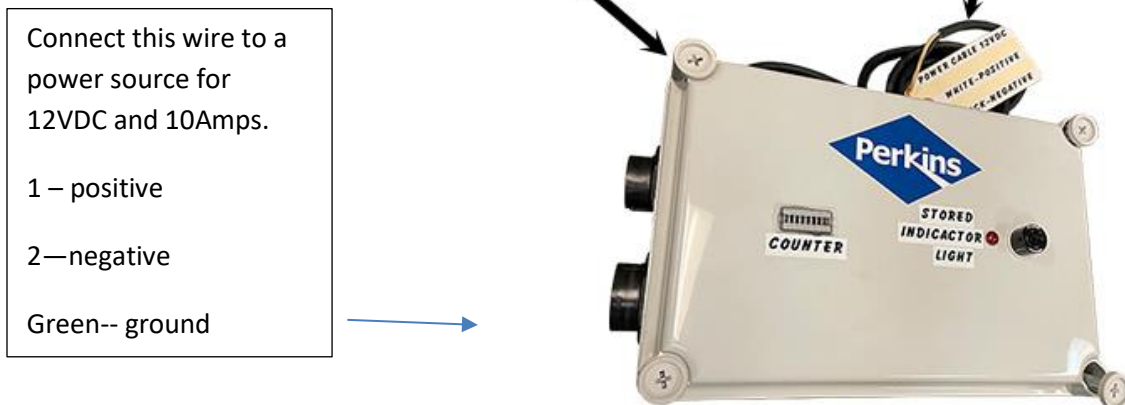

Outside of the cabin, connect the matching connectors of the harnesses (D50280) to their correspondent on harness A91164. This harnesses D50280 can come in two sizes 50ft long for bigger trucks and 25ft long for smaller. Can also be customized to the size, once installed, if you order the pins and have the tools to do it. Specialized tools like the crimper and remover will be necessary, we recommend you to buy them, once you own one of these automated units, for future service. Fish the harnesses through the truck's body and tide against static parts, free from friction, pinching and heat. Go all the way to the already installed harnesses brackets (A90298), insert the ends fittings and secure with the provided washers and nuts.

*- D50280- Harness from Chassis to valve Bank.
Connect to the correspondent connector at the chassis and fish through the outside chassis and body to the valve bank. Tide only to fix parts and free of friction against other components*



Connect the correspondent coils harness A90954 to the end of the D50280 and plug them into their correspondent coil at the bank valve as marked. Connect the DIN connectors to each individual coil at the bank valve assembly as marked.

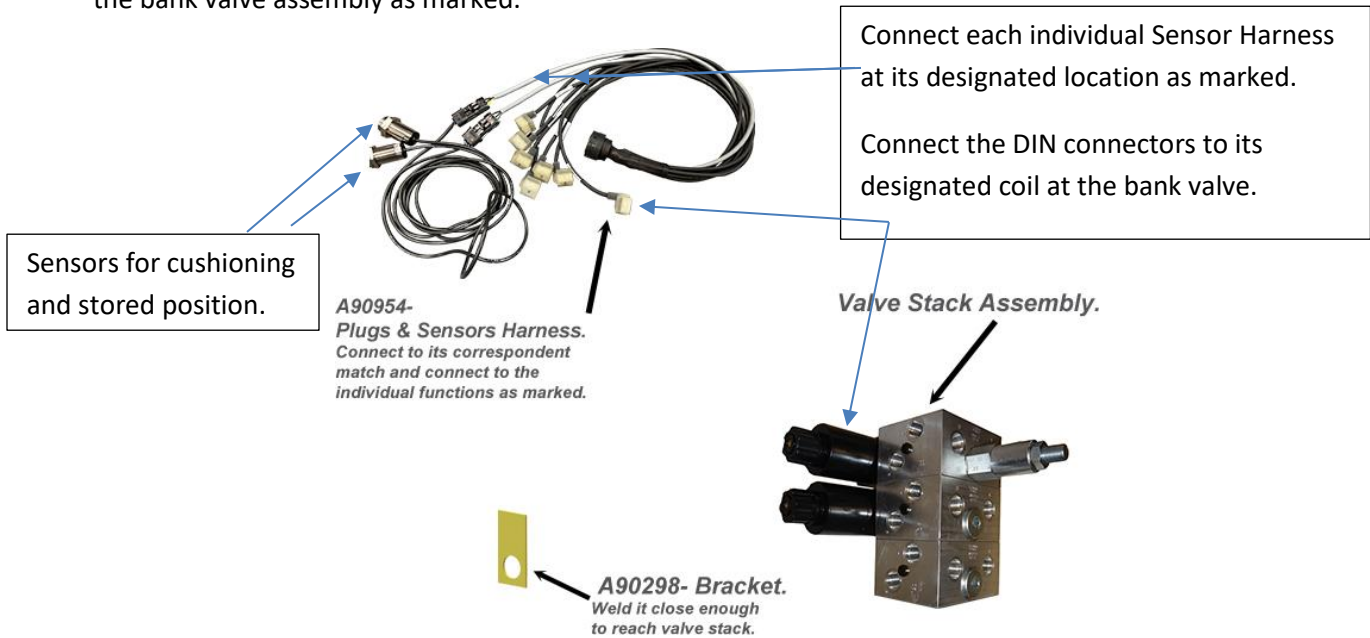

The electrical system provides two sensors, one is for cushioning the unit when retracting and the second is to detect the unit when retracted in storage position. Because of the operational speed it is important to slow down the machine when finalizes its retraction to avoid from slamming against the truck and destruct itself. The cushioning sensor needs to be installed to keep the warranty of the unit. The sensor comes installed at the end of the slide motion, but can be relocated at any other location that feels the machine is getting close to the truck. See images below.

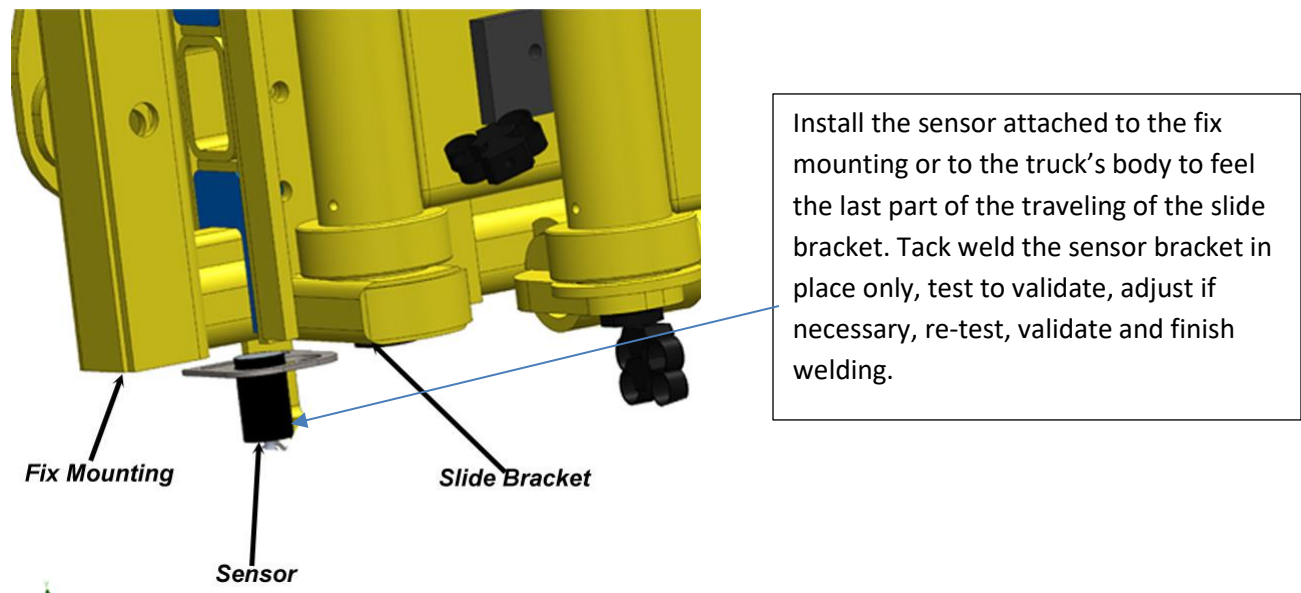

When the truck is traveling at high speeds or its not in collection mode, it is important for the operator to keep the machine in storage position. Traveling with machine out or not in storage position can cause an accident that could cause damage to the machine, third party property or injuries to people. To help with this, the electrical system is equipped with two important features, a sensor that feels the machine is stored and send a signal to a light on the electrical box for the operator to see. The best place to install this sensor is behind the grippers to feel when grippers are down and open. See image.

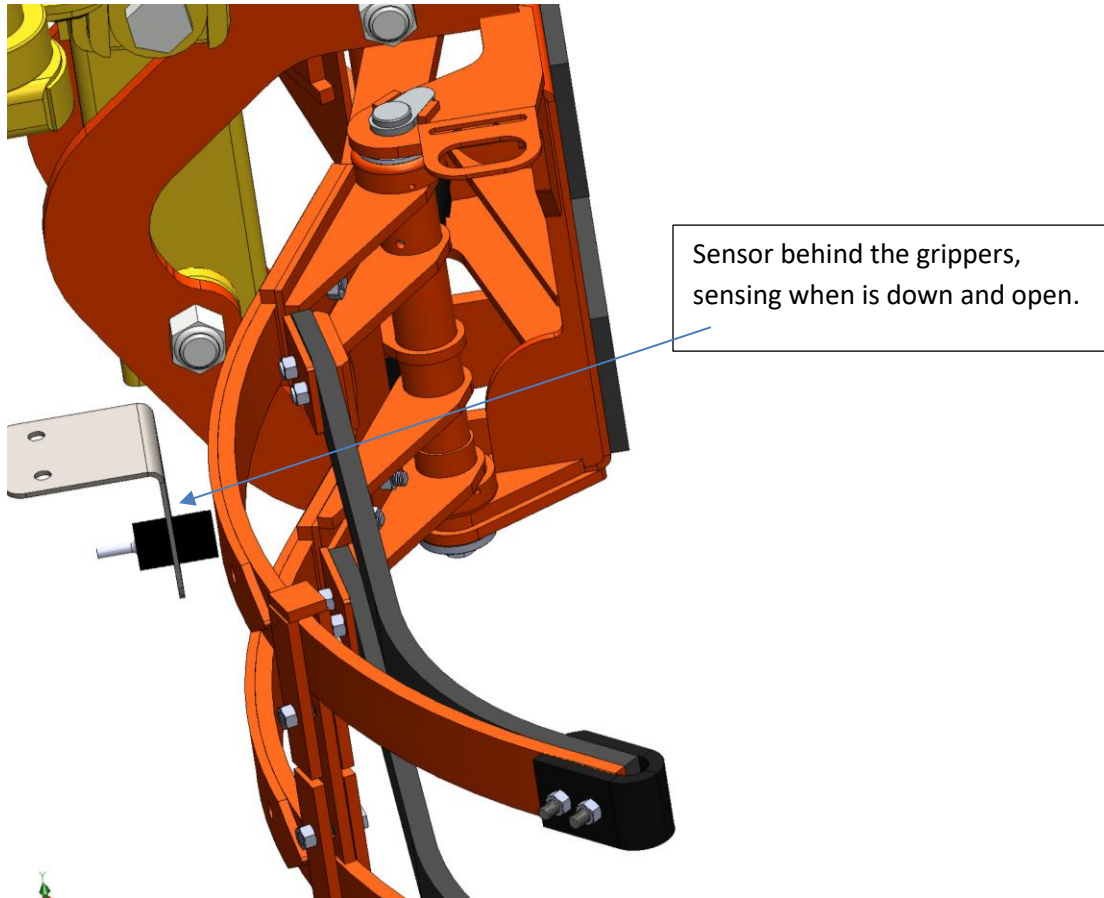

Another feature (optional) is the auto-retraction feature that automatically activate three functions simultaneously per 3 seconds (adjustable time .5 to 5sec). From the factory, this feature comes disabled and needs to be enable if customer wants this to be an option for his machines. A trigger method needs to be determined to enable, this can be triggered by the driving shift, manually by the operator, by applying the breaks, if the stored sensor does not feel the unit, etcetera.



Proportional Settings

The proportional equipment are the hydraulic valves (A90916, A90928), Electronic amplifier modules (A90926) and the Proportional Joystick (A90915). These three components work together to communicate their values, interpret them and along with operator's action of moving joystick lever side to side or front to back, act to move the machine the smoothest way possible.



As factory default, the final settings for this machine are shown in the image below. These setting can be saved in a removable USB memory card or a computer for future servicing of the machine. If changes need to be done to this setting, call Perkins service department and they will guide you on how to change and how to save your new settings. The use of specialized equipment will be necessary: a communication cable to communicate between a computer and the electronic module and a computer or lap top.

CHI PC Rev 3.2 - Configuration Tool for Digital Control Modules and Valves - Continental Hydraulics

File Edit Options Help

COM1

Command	Parameter	Help
FUNCTION	AA	Function mode [AA/A-B/RA] please press ID button after selection
LG	EN	Deutsch (DE)/English (EN) - Bitte ID Button nach der Änderung drücken
MODE	EXP	STANDARD / EXPERT mode
SENS	AUTO	Malfunction monitoring [ON/OFF/AUTO]
CCMODE	OFF	Characteristics linearization [ON/OFF]
PIN:6	USCALE	Function of PIN 6 [USCALE/RAMP]
USCALE	10000	Output current scale in 0.01%
LIM	0	Range control input signal in 0.01%
POL	+	Output polarity (+/-)
AINA		Input switching, voltage or current [V/C]
AINB		Input switching, voltage or current [V/C]
AIN:A	00 1000 0 V	Input scaling via linear equation
AA:1	100	Ramptime acceleration A in ms
AA:2	100	Ramptime deceleration A in ms
AA:3	100	Ramptime acceleration B in ms
AA:4	100	Ramptime deceleration B in ms
CC		Free definable characteristic linearization
MIN:A	1000	Compensation of the deadband in 0.01%
MIN:B	1000	Compensation of the deadband in 0.01%
MAX:A	10000	Output scaling in 0.01%
MAX:B	10000	Output scaling in 0.01%
TRIGGER	200	Trigger point of the MIN function in 0.01%
CURRENT	1880	Rated solenoid current 500... 2600 mA
DAMPL	500	Dither amplitude in 0.01% of the rated current
DFREQ	121	Dither frequency in Hz
PWM	2604	PWM frequency in Hz
ACC	ON	Auto Adjustment of the current loop [OFF/ON].
PPWM	7	P-Gain of the current loop
IPWM	40	I-Gain of the current loop

port close Port: 1 FDX CEM-AA-B -2030 -r01

Module Commands

Save

Default

LoadBack

Parameter Import / Export

Parameter Import

Parameter Export

*Example screen of how the program will look.



Perkins Manufacturing Company
 Creators of the TuckAway® Cart Lifter
www.perkinsmfg.com

800-882-5292

Revised: 6/30/21
 Page 37 of 59

For proper operation these are the settings as programmed by Perkins. Modules come preprogrammed.

```
FUNCTION AA
LG EN
MODE EXP
SENS AUTO
CCMODE OFF
PIN:6 USCALE
USCALE 4300
LIM 0
POL +
AINA
AIN:A 2000 1000 0 V
AA:1 100
AA:2 100
AA:3 100
AA:4 100
CC:-10 -10000 -10000
CC:-9 -9000 -9000
CC:-8 -8000 -8000
CC:-7 -7000 -7000
CC:-6 -6000 -6000
CC:-5 -5000 -5000
CC:-4 -4000 -4000
CC:-3 -3000 -3000
CC:-2 -2000 -2000
CC:-1 -1000 -1000
CC:0 0 0
CC:1 1000 1000
CC:2 2000 2000
CC:3 3000 3000
CC:4 4000 4000
CC:5 5000 5000
CC:6 6000 6000
CC:7 7000 7000
CC:8 8000 8000
CC:9 9000 9000
CC:10 10000 10000
MIN:A 1000
MIN:B 1000
MAX:A 10000
MAX:B 10000
TRIGGER 200
CURRENT 1880
DAMPL 500
DFREQ 121
PWM 2604
ACC ON
PPWM 7
IPWM 40
```



Please go to www.continentalhydraulics.com and download the free software into the computer that you plan to use. The electronic amplifier module needs to be powered, please refer to the electric schematic, once the module is ON the green light on the face of the module will either blink (no load detected) or remain steady ON (ready). Connect the communication cable to the computer and to the module and open the program in the computer. Open the program and click the "Connect Button", then "ID Button" will become enable, click on the "ID Button" and the computer will connect with module. Now the current settings of the module will show in the window. Modify the settings per the previous page and save or, if you have the settings already saved, click on the "Export Parameter to Module Button" open the saved settings and click save. If you want to save the settings that you just set into a drive, click on "Import Parameters from Module Button" and choose where to save, from there you can always export your saved settings to the same module or other modules.

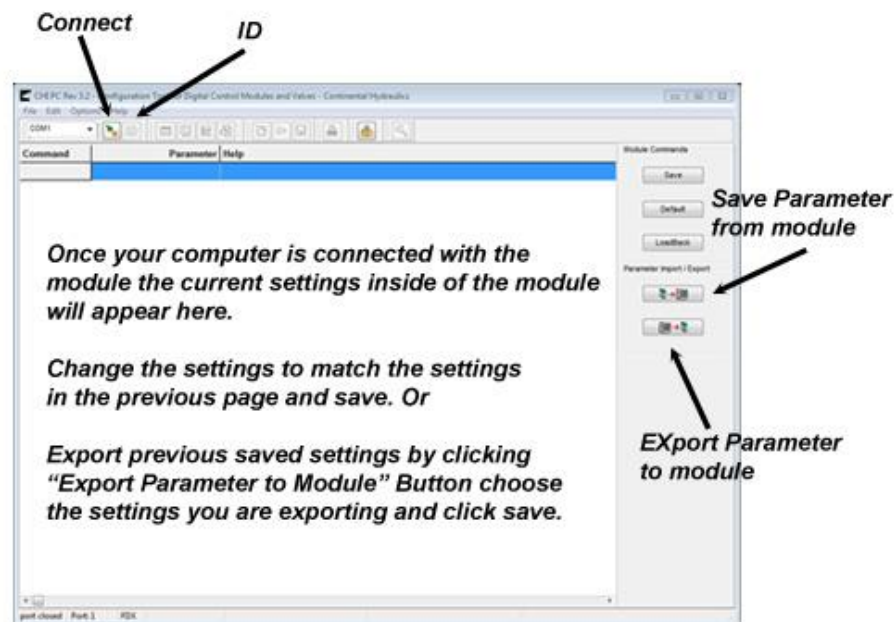
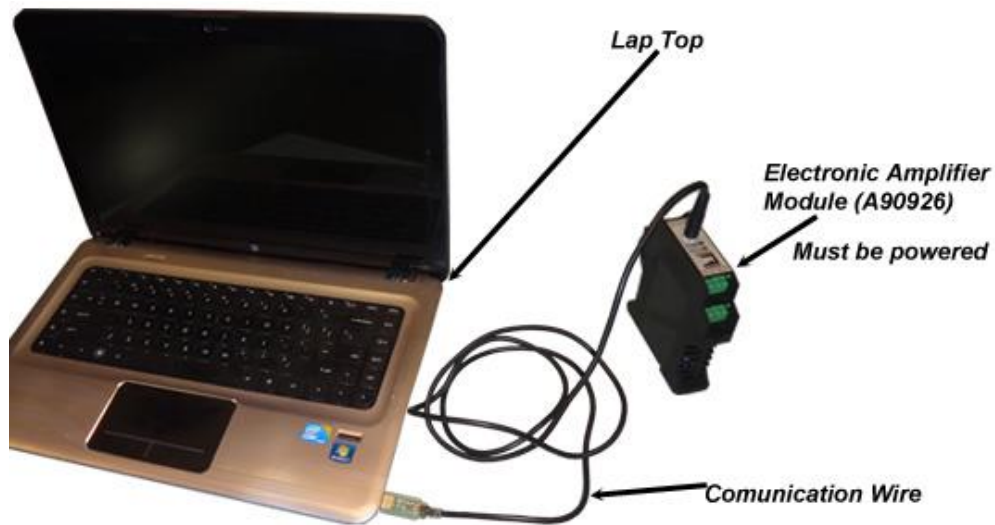

Operating the Automated Unit

The initial step before operating with hydraulic oil, will be to test that everything was connected properly. Turn on electrical power only (no hydraulic) and test the functions first with the push button station. The DIN connectors had an integrated light to show it activated. Press all the functions at the push button and verify that lights at the DIN connectors turns on accordingly. Do the same with the joy stick functions, if you activate gradually side to side and front to back you will notice how lights of the extend, retract, up and down are illuminated gradually, meaning that proportionality is working fine. Feel the stored sensor to activate light on electrical box. Activate retract with the joy stick see how the retract plug is light up and feel the cushion sensor, the retract plug should go off.

The following abbreviations were designated to name the functions and sensors.

DW- Down coil, **Up**- Up coil, **EX**- Extend coil, **RT**- Retract coil, **CL**- Close grippers coil, **OP**- open grippers coil, **PT**- Poppet coil, **STS**- Stored Sensor (Detect Grippers retracted and open), **CUS**- Cushion Sensor (Detects Machine at the final moments of its retraction movement to slow down motion)

Once proper connection has been validated the machine is ready to run. The electronic modules (in charge of translate the signals from the proportional joy stick to the proportional valve coils) has been factory set for proper operation. However, settings can always be changed (if required), please see previous pages.

Operating the Automated Unit

Turn power on with toggle switch and the green light at front of the electrical box will turn on indicating power is ready. After power, has been turned on the machine is ready to run, also at the front of the electrical box it is located:

The fuse to protect the electrical circuit, this fuse is screw in and out type and the size is of 10 amps.

The indicator lights to show if power is on, to show if the machine is retracted and, if the case, the light indicate which lifter is enabled and the switch to choose what side lifter to enable, if equipped with dual lifter.

The cycle counter, to count the number of cycles the machine has been used. This counter, counts one cycle every time the function **UP** is activated for more than 3 seconds.



Controlling the unit.

Two axis joy stick with thumb rocker switch. With the joy stick, operator can (when machine is installed at the passenger side):

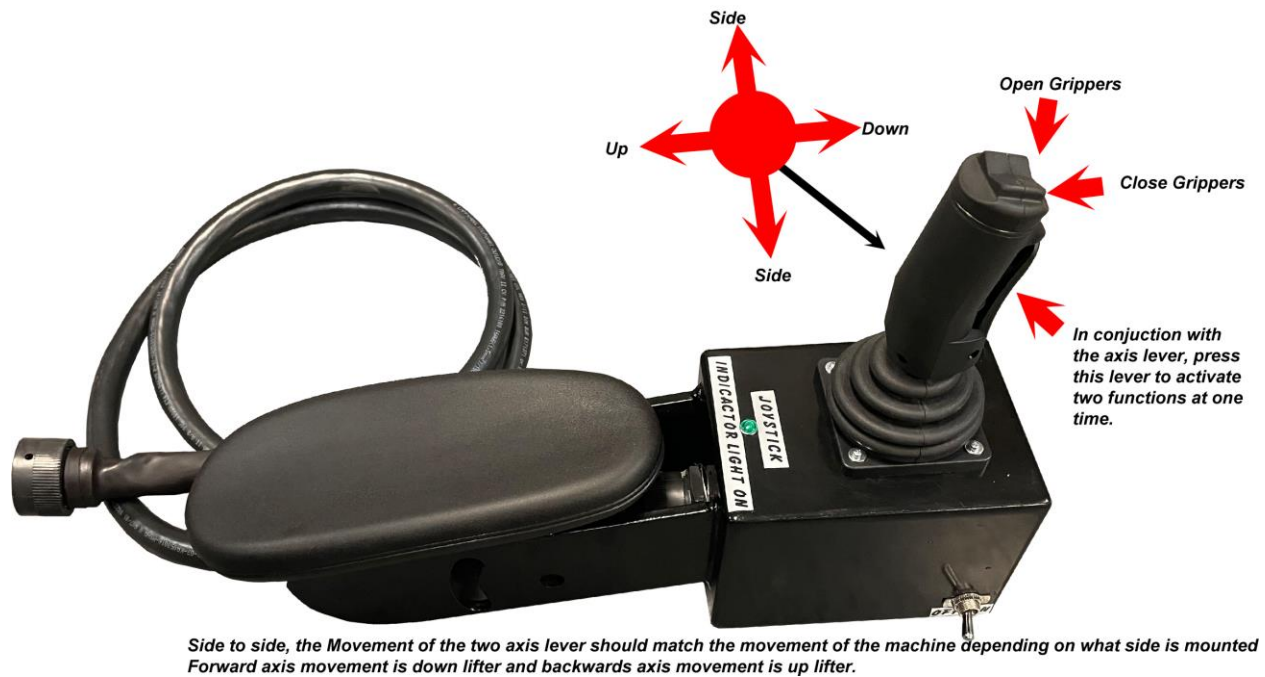

- 1- Pull the handle to the right and the frame with the grabber will travel out, if the pulling is done gradually, then the movement will increase speed gradually.
- 2- Pull the handle to the left and the frame with the grabber will travel in, if the pulling is done gradually, then the movement will increase speed gradually.
- 3- At any time during the movement the operator can release the lever and the machine will stop. And the operator can operate the grippers open or close with the thumb rocker switch located at the top of the lever to grab or release containers.
- 4- Also at any distance of the trajectory movement in or out, operator can pull the lever back to raise the grabber or push the lever forward to lower the grabber. **Warning! Operator can at any time of the movement out, in or up, down, release the container by opening the grabber.**
- 5- While operator pulls lever to move machine out, operator can also activate front trigger of lever and the machine will also move the grippers down (dual functioning).
- 6- While operator pulls lever to move machine in, operator can also activate front trigger of lever and the machine will also move grippers up (dual functioning).



- 7- Once operator has managed to secure the cart with the grabbers, the operator can activate dual functioning (as described above) and machine will retract and move up at the same time to dump. Or will extend and come back down at the same time to return the cart to its original location. **Grabbers never work automatically and are always enabled to be controllable by the operator with the upper rocker switch.**

The effectiveness of the collection relies on the comfortability, experience and knowledge that operator has with the controls and machine. The machine and controls are extensions of the operator's capabilities in a real-world application, (not a video game) real people, equipment, obstacles, etcetera are always present to consider, **safety cannot be neglected, always be aware of your surroundings.** Practice makes the experts and the time spend practicing the controls will bring speed and security to the collection. Pride of the equipment must be encouraged among the operators, customers and all the people involved in the difficult task of collecting garbage responsibly, profitable and safely for all.



SAFETY, MAINTENANCE AND SERVICE

Safe Operating Tips

Always follow your company's safety policy during the use of this equipment, including use of proper clothing/ personal protective gear, reflective clothing, etc.

Do not lift anything that grabbers can't securely grab. Damaged or oversize carts cannot be very well secured, causing them to fall from the machine, which can cause damage or injury and will void the warranty.

Do not use the equipment for any purpose other than what was designed for. Lifters are not meant as steps, they are **not to be used to lift people**, or help lift a commercial container, or used to crush/breakdown an item. Doing so can cause serious damage or injury and will void the warranty.

Speeding up the equipment beyond the recommended cycle time and/or adjusting the relief valve to pick up weights heavier than the recommended load can lead to damage or injury and will void the warranty.

Do not operate the equipment unless the area around it is clear of personnel. This means, do not touch the equipment while it is in operation and do not stand or sit under/near the equipment while it is moving. This equipment has pinch points which can cause serious injury. Stay clear always.

When inspecting the unit, make sure the hydraulics are off!



PREVENTIVE MAINTENANCE

Daily Check before beginning route:

Run the automated unit thru a couple complete cycles. Check that the unit moves correctly, that all functions respond as they should, and that there are no obviously loose or broken components. Note any dripping of hydraulic fluid, unusual sounds, or any other difficulty. Make the shop mechanic aware of any problems before going on route.

Weekly Check:

Grease all the 33 grease points using the location guide. Check all hardware. Note that everything is tight, there are no loose or missing bolts, pads, nuts, or other components.

Monthly Check:

Note any components that show signs of wear or evidence of being struck by another object. Parts that show excessive wear will need replacement or repair. Consider having spare parts available for parts that show signs of age. Commonly replaced parts include rubber pads, bolts, cylinder seal kits, bearings, rollers, etc.

NEW USER CHECK:

When placing the unit into the hands of an individual who has not worked with the unit before, it is an excellent safety idea to replace any warning labels on the automated unit that may have become worn or unreadable. All users should read and understand the manual and read thru the safety portion especially, before using the unit.



Wear Items

There are parts considered wear items because of their constant friction and/or contact within itself or other external items during functioning. Under normal operation these items must likely will be the first to wear out before anything else in the machine. As recommendation, you can have at list one replace set of these parts available in stock and visually inspect regularly to detect any unusable item that may cause further damage to other parts and cause bigger problem or delay. See below for wear parts.

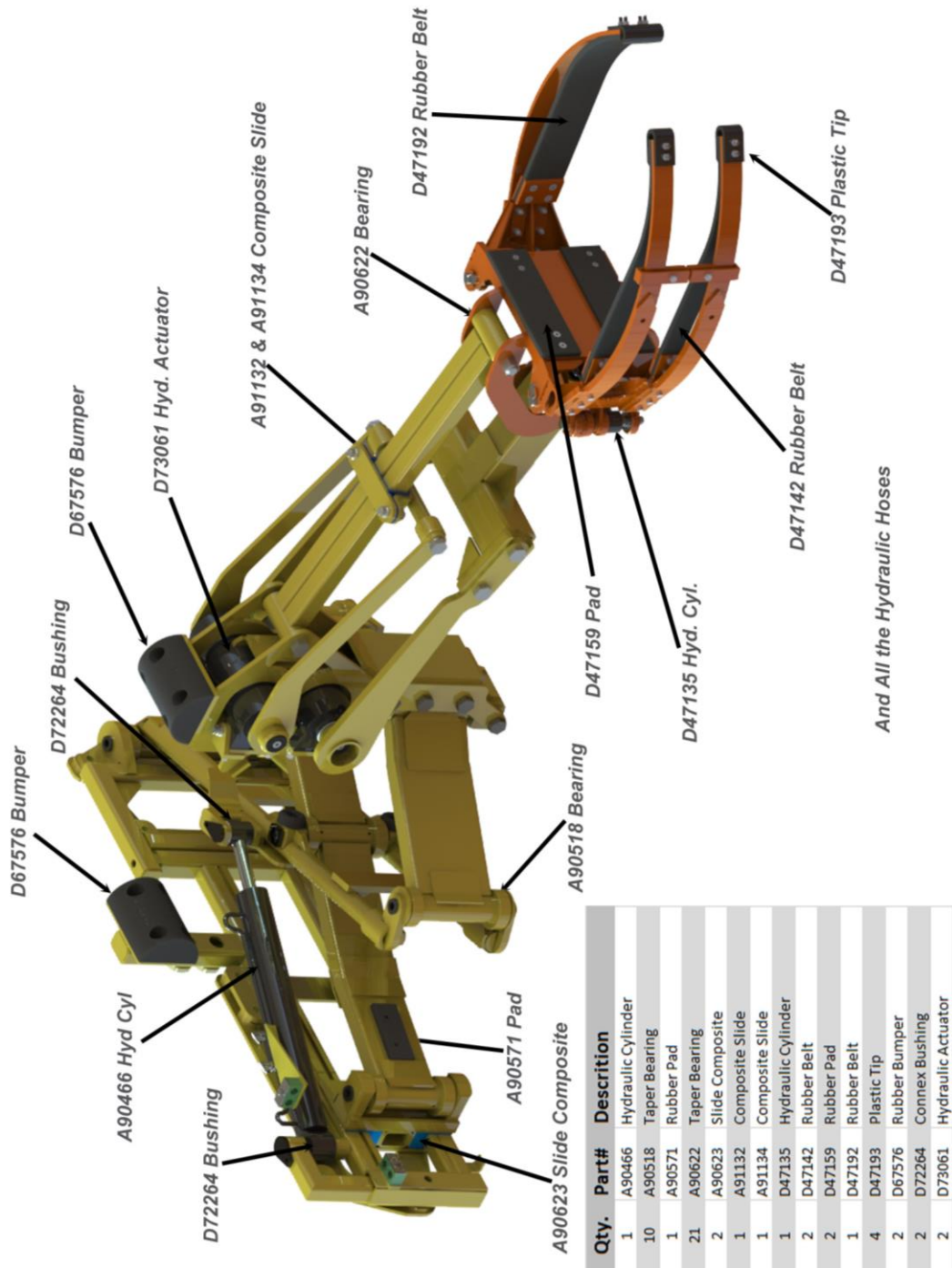

Grease Points and types of pivots



D47010
Taper Bearing
2.25" ID
Places 3 to 12.



A90622
Taper Bearing
1.25" ID
Places 13 to 32



D72264
Connex Steel
Bushing 1" ID x 1" LG.
Places 1, 2 & 33.

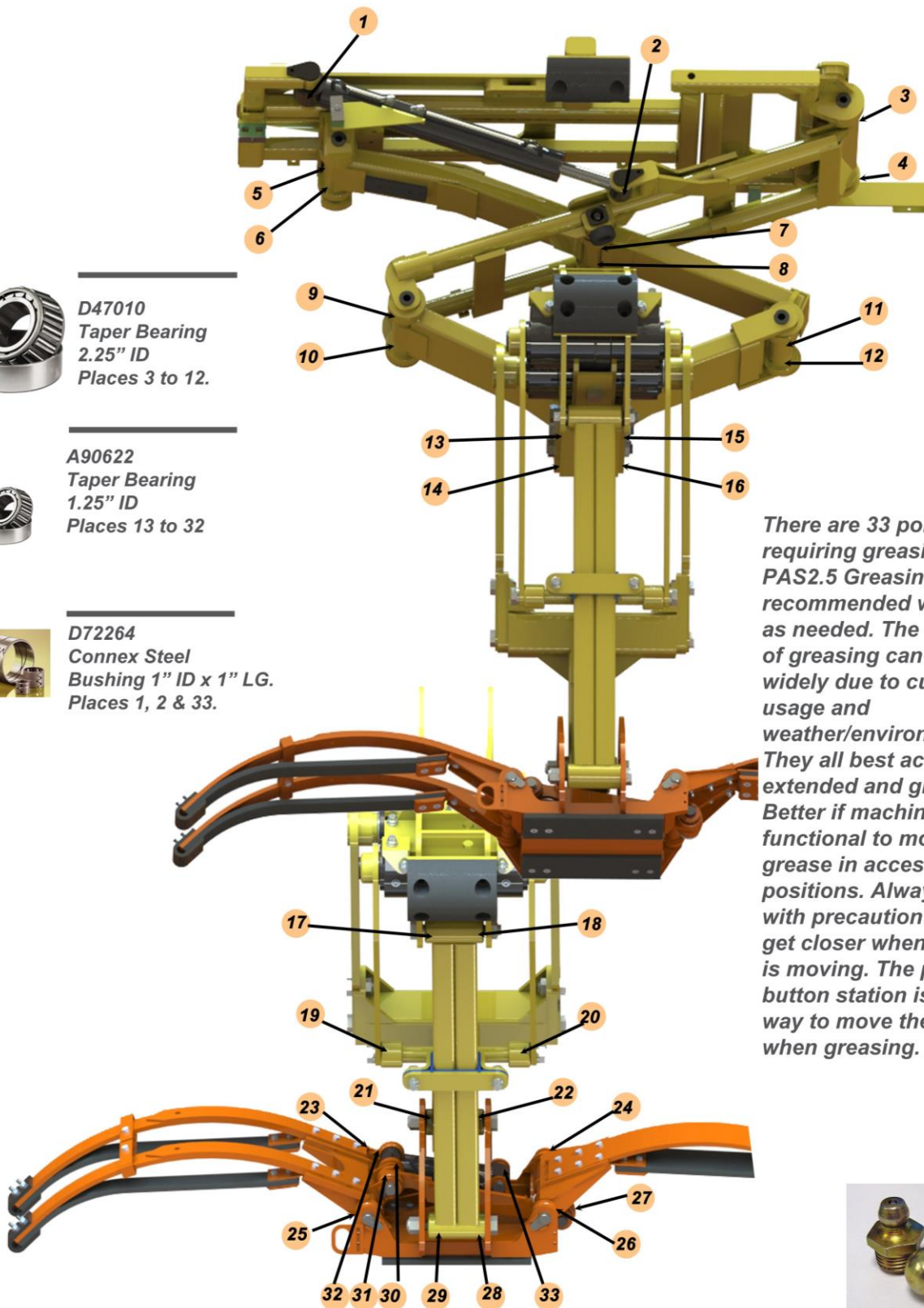

There are 33 points requiring greasing on the PAS2.5. Greasing is recommended weekly, or as needed. The regularity of greasing can vary widely due to customer usage and weather/environment. They are best accessed extended and grippers up. Better if machine is functional to move and grease in accessible positions. Always work with precaution and never get closer when machine is moving. The push button station is the safer way to move the machine when greasing.



Main Exploded View

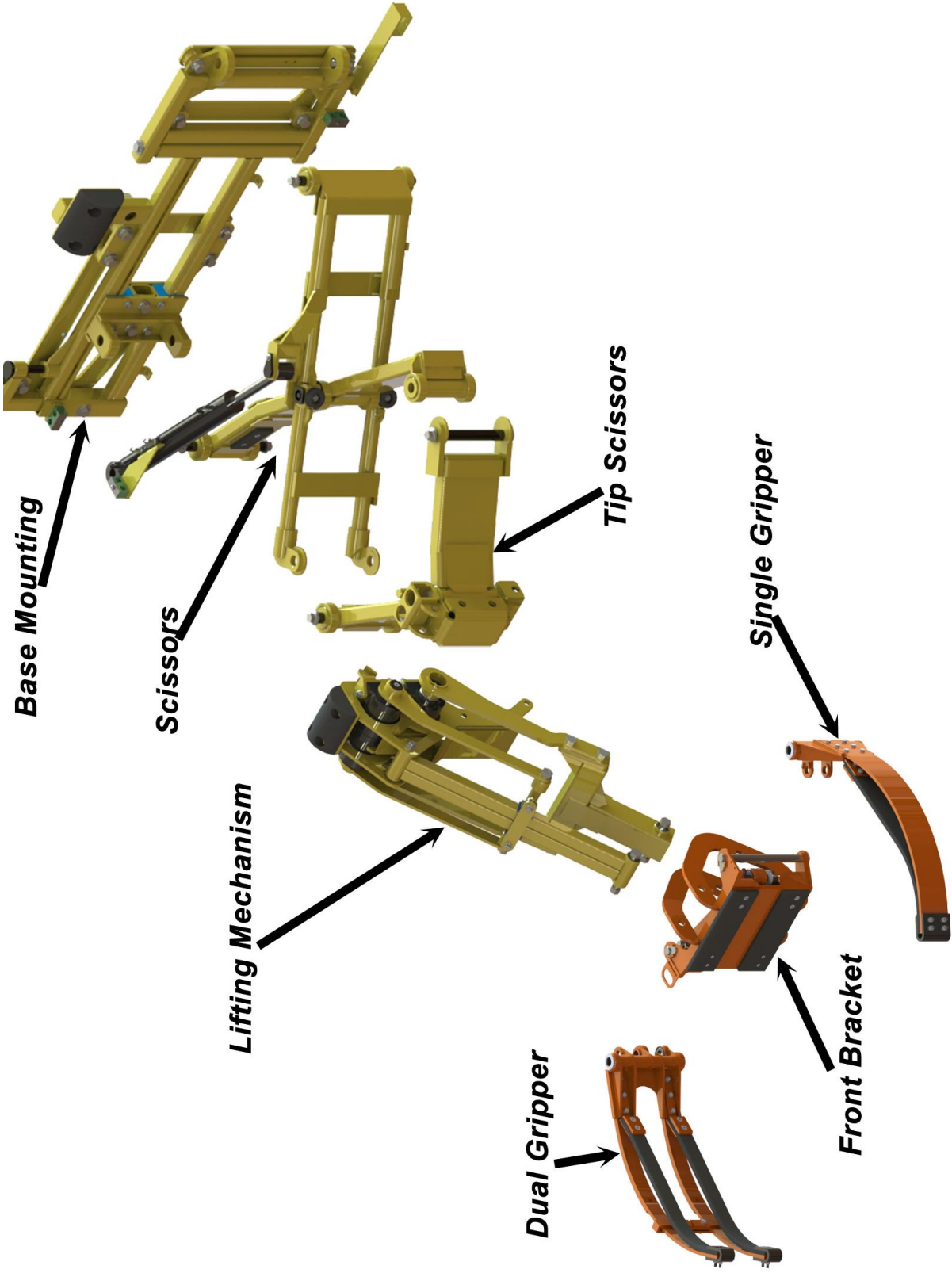

Base & Mounting Exploded View

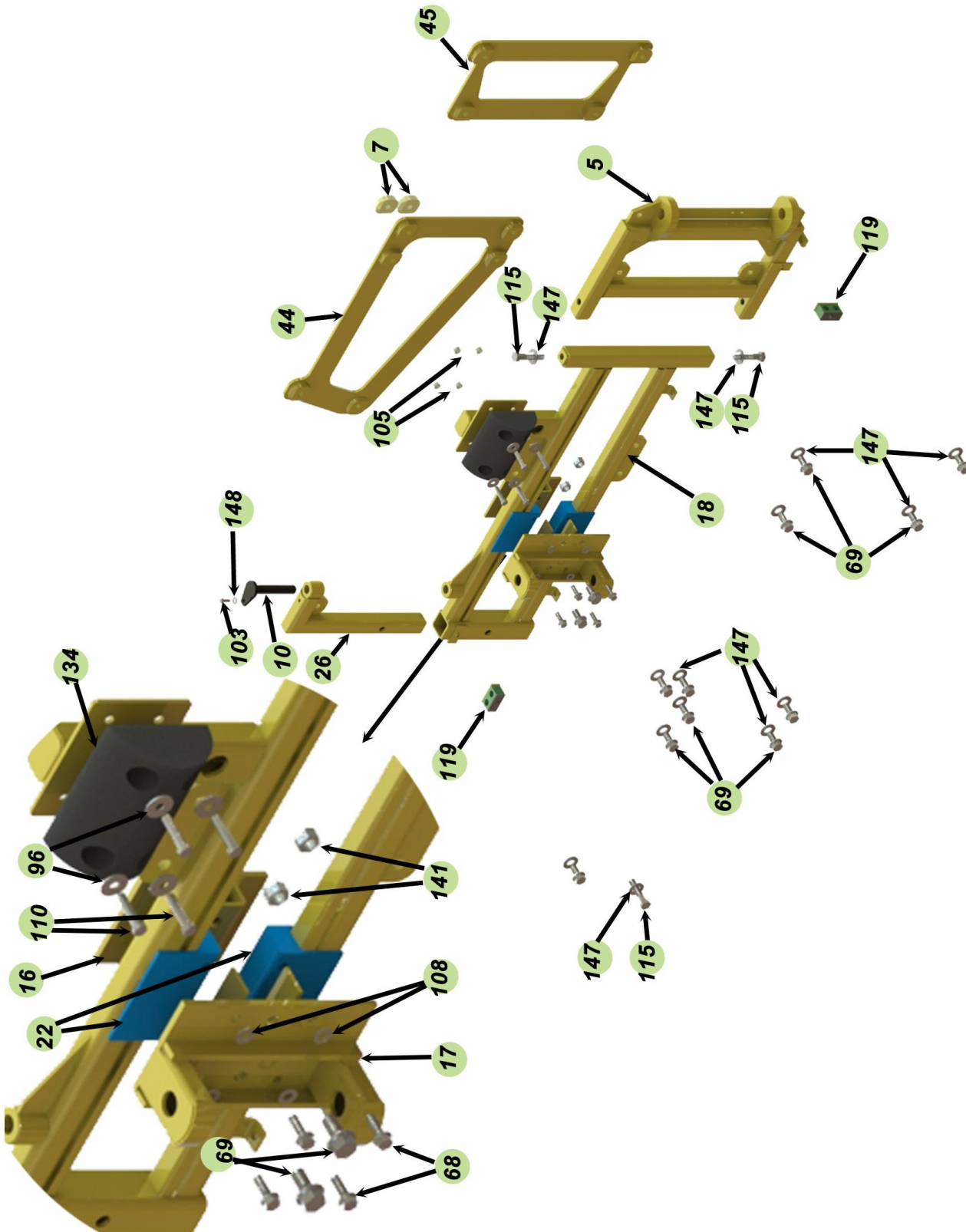

Front Bracket Exploded View

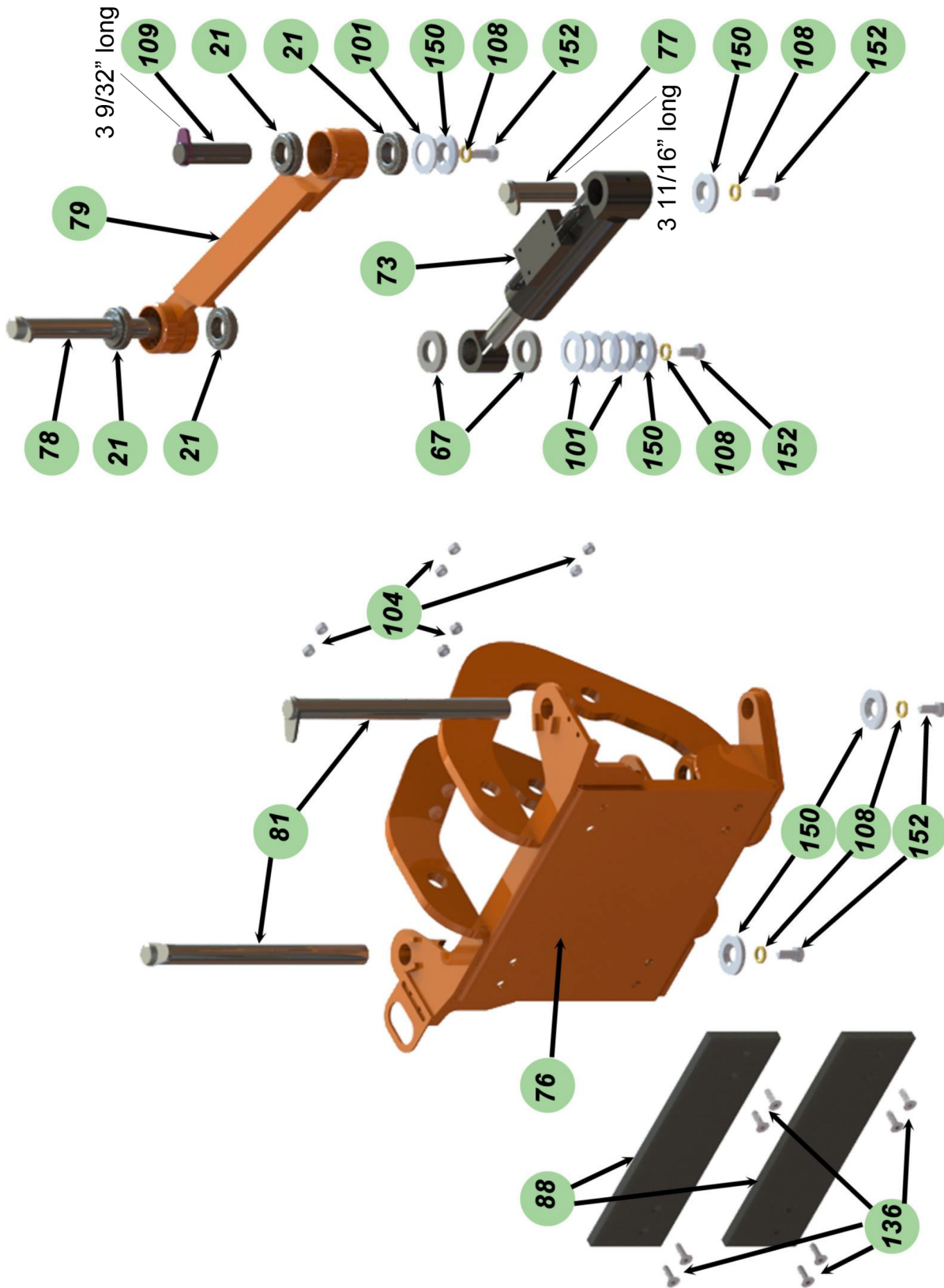

Dual Gripper Exploded View

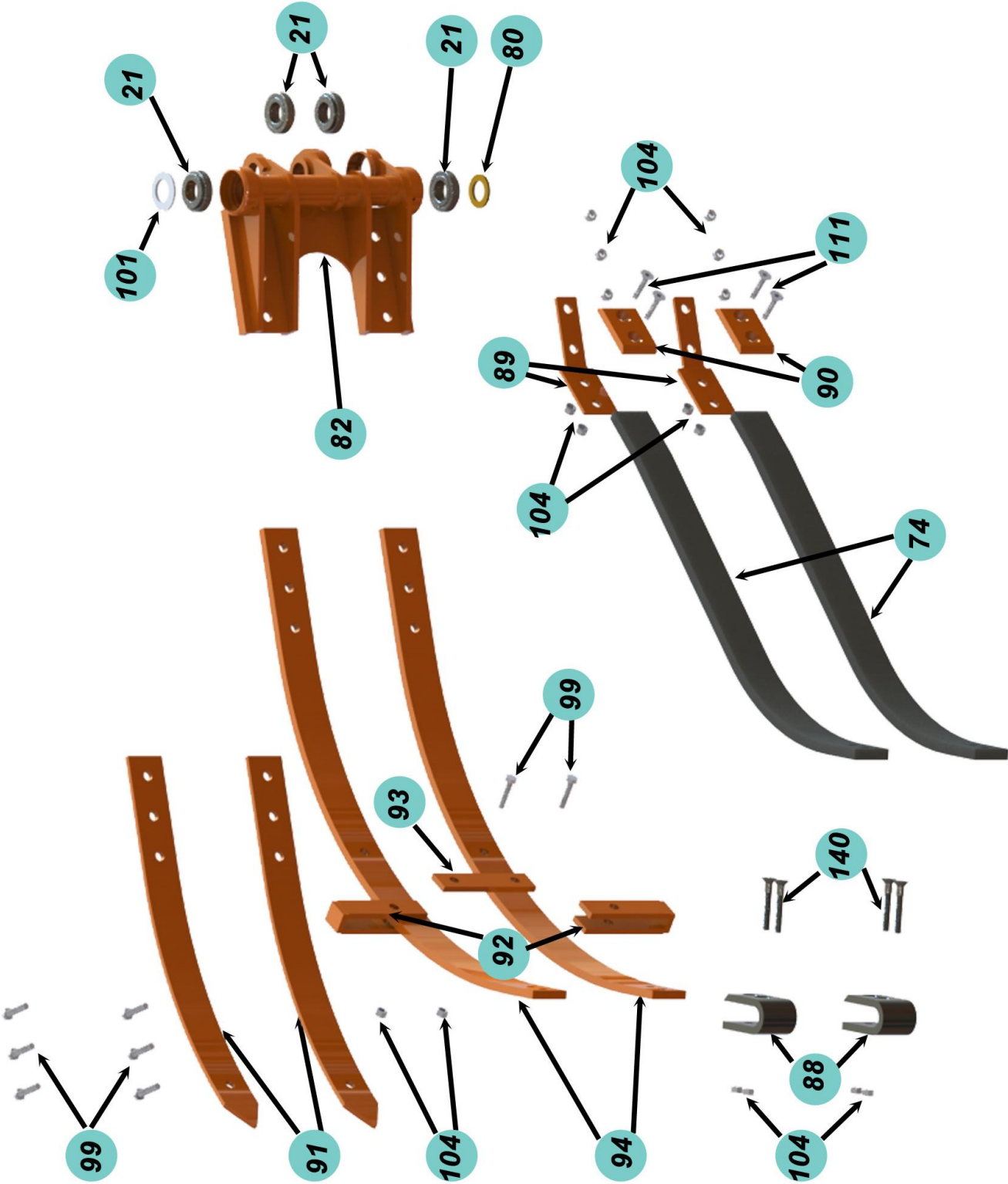

Single Gripper Exploded View

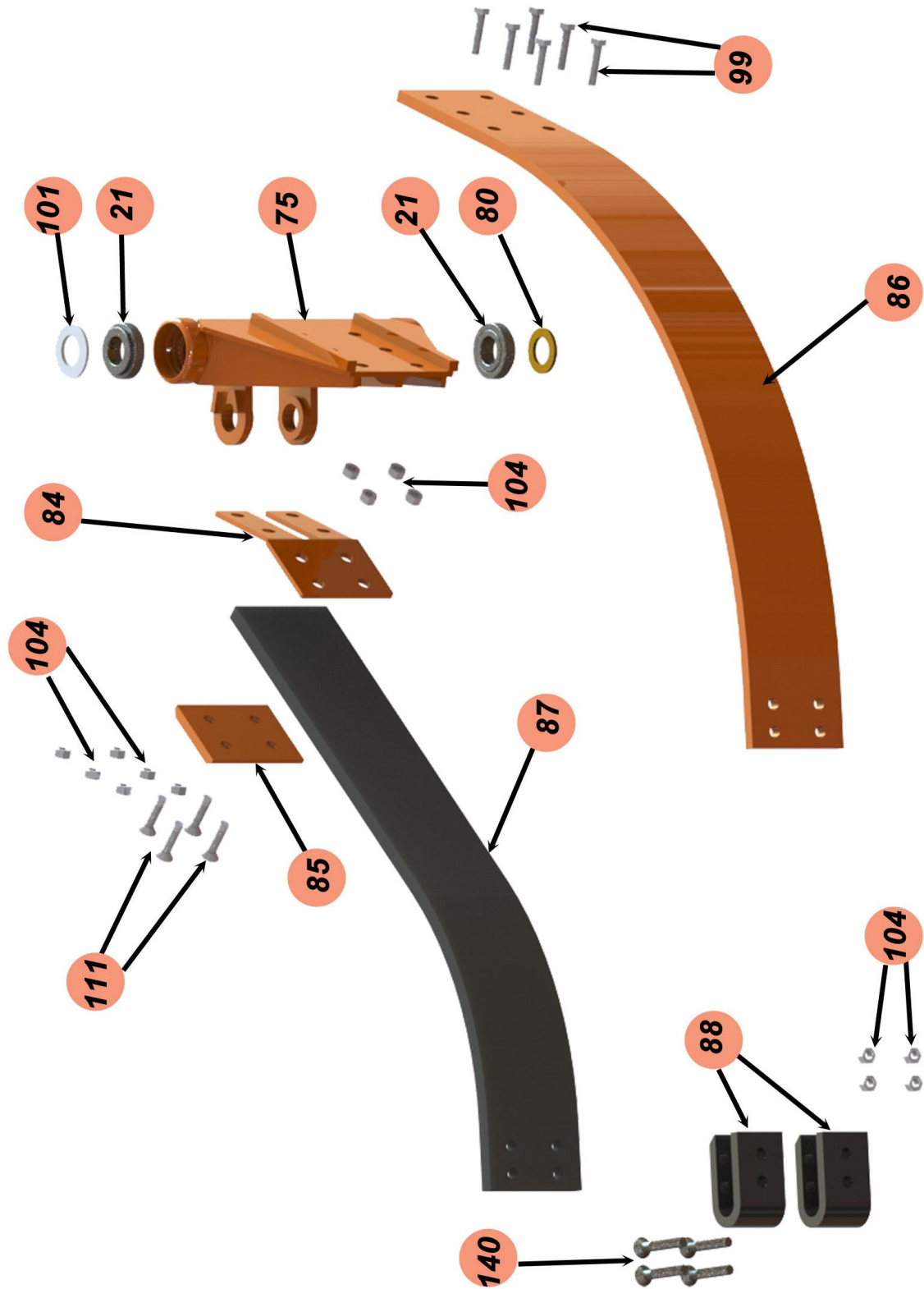

Parts List

Item	Part No	Description	QTY.
1	A90173	Rubber Bumper Small	2
2	A90270B	Solenoid valve A,B to Tank	1
3	A90270C	Pressure Relieve Cartridge	1
4	A90466	Hydraulic Cylinder	1
5	A90501 *	Frame Weldment	1
6	A90518	Tapered Roller Bearing	10
7	A90561	Back Threaded Plate	2
8	A90571	Front Rubber Pad	1
9	A90583	Cylinder Pin Small	1
10	A90584	Cylinder Pin large	1
11	A90587	1 5/16 x 10 1/4 Pin	1
12	A90588	1 5/16 x 11 5/8 Pin	1
13	A90589	1 5/16 x 12 1/4 Pin	1
14	A90590	1 5/16 x 17 3/8 Pin	1
15	A90591	1 5/16 x 12 3/4 Pin	1
16	A90599	Slide Back Plate	1
17	A90602	Slider Bracket Weldment	1
18	A90604 *	Slider Weldment	1
19	A90608	U Cup Seal	10
20	A90614	Bolt HHCS 1-8x10-1/2	2
21	A90622	Tapered Roller Bearing	22
22	A90623	Nylon 6 MD + Oil Slide	2
23	A90628	Inside Tube Assy.	1
24	A90630	Front Tube LH Assy.	1
25	A90631	Front Tube RH Assy.	1
26	A90632 *	Cyl. Bracket Assy.	1
27	A90699 *	Clamp plate	1
28	A90706	Valve bracket weldment	1
29	A90720 **	Sidewinder hose wrap	3
30	A90722	Retainer w/Lock disc	9
31	A90750 **	PAS Label Kit	1
32	A90757	Double P.O. Check #8	2
33	A90758	Adapter str. #8MO-#6FT	1
34	A90809	Pilot Operated Valve N.O.	1
35	A90833 *	Outside Tubes Weld	1
36	A90877-10	Hose Assembly #6 x 10"Lg.	3
37	A90877-105	Hose Assembly #6-105"Lg.	2
38	A90877-26	Hose Assembly #6 x 26 Lg.	2
39	A90877-30	Hose Assembly #6 30"Lg.	4
40	A90877-32	Hose Assembly #6-32"lg	12



Parts List Continued

<u>Item</u>	<u>Part No</u>	<u>Description</u>	<u>QTY.</u>
41	A90877-37	Hose Assembly #6-37"Lg	2
42	A90877-55	Hose Assembly #6 x 55 Lg.	1
43	A90877-64	Hose Assembly #6-64"Lg	1
44	A90893*	Back Mtg. Weldment	1
45	A90894	Back Mtg. Weldment	1
46	A90901	Valve Bracket	1
47	A90916	Proportional 3-way Valve	1
48	A90928	Closed Center Proportional Valve	1
49	A90954	Proportional Plugs Harness	1
50	A90973	Fittings Plate	2
51	A90982	Fittings Plate	2
52	A91105	Center Drive Weldment	1
53	A91115	LH Driver Arm Weld	1
54	A91120	RH Driver Arm Weld	1
55	A91122	RH Bolt On Plate	2
56	A91125	Idler Tube Weldment	1
57	A91127	LH Bolt On Plate	2
58	A91132	Composite Slide	1
59	A91133	Cover Plate	1
60	A91134	Top Composite Plate	1
61	A91135	Slide Weldment	1
62	A91140	RH Auxiliary Driver Weldment	1
63	A91145	Mounting Bracket Weldment	1
64	A91150	Mounting Bracket Weldment	1
65	A91155	Clamping Weldment	1
66	A91160	LH Auxiliary Driver Weldment	1
67	A91183	Spacer Boss	2
68	D38036	FLANGE HEAD 1/2-13 X 1 1/2	4
69	D38039	FLANGE HEAD 3/4-10 X 1 1/2	22
70	D47095	Valve Aluminum Manifold	3
71	D47095-1 **	Internal Hydraulic Seal	4
72	D47095-2	5/16-18 Threaded Rod	3ft
73	D47135	Hydraulic Cylinder	1
74	D47142	Rubber Belt Small	2
75	D47254	Single Gripper Base Weld	1
76	D47150	Grippers Frame Weld	1
77	D47152	Pivot Pin 3 11/16" long	1
78	D47153	Pivot Pin	1
79	D35020	Linkage Weldment	1
80	D47156	Brass Pad	4
81	D47157	Pin Large	2



Parts List Continued

<u>Item</u>	<u>Part No</u>	<u>Description</u>	<u>QTY.</u>
82	D47255	Double Gripper Base Weld	1
83	D47159	Front Pad	2
84	D47189	Bolt On Plate	1
85	D47190	Top Plate	1
86	D47191	Single Gripper Plate	1
87	D47192	Rubber Belt Lg.	1
88	D47193	Tip Plate	4
89	D47194	Bolt On Plate	2
90	D47195	Bottom Plate	2
91	D47196	Back Plate	2
92	D47197	Center Bracket Weld	2
93	D47198	Spacer plate	1
94	D47199	Double Gripper Plate	2
95	D62006	BOLT FHCS 1/2-13 X 1 1/4	4
96	D62008	SAE FLATWASHER 1/2"	4
97	D62030	LOCKNUT 5/16-18	8
98	D62036	BOLT HHCS 1/4-20 X 1 1/2	2
99	D62038	BOLT HHCS 3/8-16 X 1 1/2	14
100	D62044	BOLT FHCS 3/8-16 X 1 1/4	8
101	D62062	SAE FLATWASHER 1"	7
102	D62071	LOCKNUT 1-8 - 7/8" high	5
103	D62079	BOLT HHCS 3/8-16 X 1	10
104	D62080	LOCKNUT 3/8-16	41
105	D62081	LOCKNUT 1/2-13	4
106	D62082	BOLT HHCS 1/2-13 X 1 1/2	4
107	D62085	BOLT HHCS 3/8-16 x 1 3/4	4
108	D62104	LOCKWASHER 1/2" NORDLOCK	10
109	D47257	PIVOT PIN, 3 9/32" LONG	1
110	D62112	Bolt HHCS 1/2-13 x 2 1/4	4
111	D62420	BOLT FHCS 3/8-16 X 1 1/2	8
112	D62449	BOLT HHCS 1/4-20 X 3"	2
113	D62457	LOCKNUT 1/4-20	4
114	D38040	NORDLOCK LOCKWASHER 5/8"	12
115	D62473	BOLT HHCS 3/4-10 X 3 1/2in LG.	3
116	D62484	USS FLATWASHER 1/2"	4
117	D62491	BOLT HHCS 1-8 X 8 1/2"	1
118	D63011	ELBOW 90 #6MT-#6MO	7
119	D63014	HOSE CLAMP SET #8	3
120	D63015	Elbow 90 #6MT - #6MO long	3
121	D63031	Tee #6MO -#6MT- #6MT	2



Parts List Continued

<u>Item</u>	<u>Part No</u>	<u>Description</u>	<u>QTY.</u>
122	D63061	ADAPTER #6MT-#8MO	1
123	D63074	ADAPTER #6MT-#6MO	19
124	D63106	ELBOW 90 6MT-6FT	1
125	D63138	Tee #6MT - #6MT - #6FT	1
126	D63218	Tee #6MO- #6JIC- #6JIC	2
127	D63238-9	EXTERNAL HUB SEAL	4
128	D63431	REDUCER #6FT-#8MT	2
129	D63575P	Adjustable Flow Control Parker	5
130	D63597	ADAPTER #6MO-#6FT	5
131	D63612	Pressure Relief Valve	1
132	D63613	Inline Check Valve	1
133	D63615	Check Valve for Cylinder	1
134	D67576	Rubber Truck Bumper	2
135	D68081	BKHEAD ADPT #6MT-#6MT	12
136	D72005	BOLT FHCS 3/8-16 X 1	8
137	D72013	BOLT Fla-H 3/4-10 X 2	2
138	D72071	BOLT HHCS 1-8 x 2	4
139	D62012	ROLL PIN 1/4" X 1"	2
140	D72101	BOLT FHCS 3/8-16 X 2 1/2 GR8	8
141	D72132	LOCKNUT 3/4-10 ZIN PLATED GR 8	4
142	D72135	BOLT HHCS 1-8 X 7.5"	7
143	D72208	LOCKNUT 1-8-THIN 1/2"	9
144	D72212	Bolt HHCS 1-8 x 3-1/2"	2
145	D72219	12pt Flange Bolt 5/8-11 x 1.5	12
146	D72234	HHCS 1/4-20 X 3/4	2
147	D72464	NORDLOCK LOCKWASHER 3/4	23
148	D72465	NORDLOCK LOCKWASHER 3/8	8
149	D72476	NORD-LOCK 1/4" LOCKWASHER	2
150	D73008	Actuator Flange	9
151	D73060HKS	27K Split Body Actuator	2
152	D77159	BOLT HHCS 1/2-13 X 1	5
153	Z102 **	Grease Zerk Str 1/4-28	33
154	D63105	Elbow 90 #8MO - #6MT	2

***Add RH or LH to Part# per the side is mounted.**

**** Not Shown.**



Making a Warranty Claim

For complete warranty coverage details, please see the warranty page at the end of this manual.

If you suspect that failure of the lifter to operate is due to a defect, please take a moment to locate the serial number of your lifter.

Warranty cannot be honored on lifters or individual pieces unless a serial number is provided. Since the tag is frequently lost, damaged, or painted over, it is a good idea to note the serial number in this manual at the time of installation.

At right are two examples of serial number plates. It will be stamped with a model number and serial number.

Warranty coverage does not apply to collisions, operator errors or neglect. Warranty does not cover shipping costs, labor to replace parts, downtime, etc. Further details can be found on the warranty page.

Once you have the number, please call Perkins Manufacturing at 800-882-5292 for additional instructions.



Protective Safety Labeling

Perkins provides each finished cart lifter with ANSI-specified caution labels. They are clearly placed directly on the machine for easy viewing by the operators.

Should the cart lifter ever be re-painted, or if the labels are damaged beyond recognition, it is advised to replace the labels immediately to help keep your crew safe.

OHSA always requires these labels to be in clear sight on the machine.

Responsibility to maintain proper caution and warning labels is the responsibility of the end-user.



You should make sure that all pressure is bled/released from the hydraulic or pneumatic system; for some systems it may be possible to work on a part of the system by using line-breaking or blanking procedures. Never loosen or tighten a hydraulic connection when the system is under pressure. The connection could fail catastrophically and cause an injection injury and/or damage to property. Inspect hoses regularly for wear then replace hoses before leaks can develop. Hydraulics systems should look clean and dry. You can typically see leaks where the machine is collecting dirt and debris that is sticking to the oil. Look for wet-looking areas that are collecting dirt. Check for abraded/scuffed hoses, loose or damaged fittings, or worn out seals, or other physical damage that may have led to creating the leak.



⚠️ ATENCIÓN		⚠️ CAUTION
Punta Peligrosa. Mantenga las manos alejadas.		Pinch point hazard. Keep hands clear.
© Perkins Manufacturing Company 800-882-5292 Label # D72496		

<h1>NOTICE</h1>	
Maintenance Requirements	
	<p>Read and understand manual prior to operating this equipment.</p> <p>Follow maintenance guidelines per the manual. Inspect machine daily prior to use and report any problems to service immediately.</p> <p>Failure to operate and maintain the unit within guidelines will void the warranty.</p>
<div style="display: flex; justify-content: space-between;"> Perkins Manufacturing Company 800-882-5292 www.perkinsmfg.com Label # D72495 </div>	

⚠️ PELIGRO		⚠️ DANGER
Manténgase alejado del levantador. Un golpe causaría lesiones o la muerte.		Stand clear of lift. Contact will cause injury or death.
© Perkins Manufacturing Company Label # D72497		

⚠️ CAUTION		⚠️ ATENCIÓN
Pinch points and crush hazards. Stand clear during operation. Worker can be injured by moving parts.		Puntos de pellizco y riesgos de aplastamiento. Manténgase alejado durante la operación. El trabajador puede resultar lesionado por Partes que se mueven.
<div style="display: flex; justify-content: space-between;"> PERKINS MANUFACTURING CO. 708-482-9500 D62474 </div>		

Dress appropriately for work with pants and sleeves that are not too long or too loose. Shirts should be fitted or tucked in. Avoid wearing loose and dangling jewelry. Tie back long hair and tuck braids and ponytails behind you or into your clothing. Wear the appropriate, well-fitting gloves for your job.

Look for possible pinch points before you start a task. Take the time to plan out your actions and decide on the necessary steps to work safely. Read and follow warning signs posted on equipment.

Machinery can pose a hazard with moving parts, conveyors, rollers, and rotating shafts. NEVER reach into a moving machine. Turn equipment off and use lockout/tagout procedures before adjusting, clearing a jam, repairing, or servicing a machine.





	NOTICE
	<p>Grease all zerks on a weekly basis to maintain warranty.</p> <p>Re-grease after power washing.</p>
<p>Visit www.perkinsmfg.com for important updates.</p>	
<p>Please read the manual prior to operating or adjusting this machine for important information.</p>	

Perkins Manufacturing, Company 708 482 9500

Label # D72163

Maintaining the lifter is vital to ensure proper operation of the equipment and for warranty to be valid. Inspection of the lifter is also important to make sure there are no loose parts and that the lifter is properly greased. Not inspecting or maintaining the machine regularly can pose a hazard of parts coming loose, parts not moving properly or wear items to become too worn to not move properly. If any issues occur, please contact service immediately.

 <p>ATENCIÓN</p> <p>Superficie caliente. Los componentes pueden alcanzar +170 grados. No tocar.</p>		 <p>CAUTION</p> <p>Hot surface. Components can reach +170 degrees. Do not touch.</p>
©Clarion Safety Systems, LLC clarionsafety.com 17044		Reorder No. D72524





Label # CA1078

© Perkins Manufacturing Company 800-882-5292



Safety Labeling and Training Requirements

Perkins provides safety labeling on all outgoing product per ANSI regulations, seen below.

19-01 Warning, Label and Safety Instructions.

Include standard safety instructions as one of the first items in a manual. This helps emphasize safe use of the product and can help the user understand the hazards, the consequences of the hazards and how to avoid the hazards. Priority placement also increases the likelihood that the information will be read. Any symbols or pictograms physically on the product should be included in the appropriate section of the manual to reinforce the association between the nature and severity of the hazard and the correct behavior.

The American National Standards Institute (ANSI) standard Z535.6, *Product Safety Information in Product Manuals, Instructions, and Other Collateral Materials*, should also be applied.

To help ensure the product user sees and understands warnings and safety instructions, you should make them conspicuous. It is critical that you make proper use of the signal words "*danger*", "*warning*", "*caution*" and "*notice*" and their corresponding signal colors *red*, *orange*, *yellow*, and *blue*.

Choosing the appropriate signal words and colors are based on an estimate of the likelihood of exposure to the hazardous situation and what could happen as a result of exposure to the hazard. The American National Standards Institute (ANSI) standard Z535.4, *Product Safety Signs and Labels*, defines the hazard signal words as follows:

DANGER: Indicates an imminently hazardous situation which, if not avoided, "will" result in death or serious injury. This signal word is to be limited to the most extreme situations.

WARNING: Indicates a potentially hazardous situation which, if not avoided, "could" result in death or serious injury.

CAUTION: Indicates a potentially hazardous situation, which, if not avoided, "may" result in minor or moderate injury. It may also be used to alert against unsafe practices.

NOTICE: Indicates information considered important, but not hazard related (e.g., messages relating to property damage).

It is the responsibility of owner of this product to maintain the safety labels, keep them clear & visible to all users, and replace the safety labels when they become worn or missing.

All users must read and understand this manual and the safety precautions before using this product.



Before claiming warranty for an issue, a customer should call our service team and perform a reasonable amount of guided troubleshooting with our service technician to rule out any simple problems / easy fixes / user error.

The majority of issues are usually resolved after a few simple double checks. The goal of troubleshooting is to get your equipment up and running as soon as possible, saving time and money.

Perkins Warranty Procedure

This procedure for claiming warranty must be followed or warranty will not be approved, credit will not be issued, and replacement parts will not be shipped. This document is not a replacement for the warranty policy. Please refer to the last page of your manual, which describes the warranty policy in detail.

If you believe your Perkins lifter has suffered from a failure that could be covered by warranty, immediately lock out any equipment that has failed per OSHA guidelines.

Take photographs of the lifter, including overall views of the unit and some close-ups, as necessary to properly record the failure in a way our engineering staff can examine. While taking photos of the lifter, record the serial number of the lifter.

Call Perkins at (800) 882-5292 and ask to speak to the service department. Requests for warranty can also be emailed to svaldez@perkinsmfg.com. Attach any photos to the email, as necessary. The service department will use the photos to determine if the return of parts for inspection is necessary or not. If the return of parts is required, the service department will issue you an RGA number.

Your replacement parts will be shipped at the time of your warranty request, but they will require a purchase order number/payment in order to ship. (Credit will be issued later, after warranty status is determined.) Your replacement parts will feature RGA numbers on the documentation referencing your warranty request. Replacements are sent UPS ground. For faster shipping, the customer will be charged.

Clearly mark the box of any returns with the provided RGA number in a prominent place. This helps our shippers identify your items. When your returned parts arrive, our service and engineering teams will inspect your shipment and determine if the failure is a defect covered by the warranty or not. If the item(s) are covered by warranty, credit will be issued. If the item(s) were not covered by warranty, a report will be generated that fully describes the reasoning behind the decision.

Common Warranty Mistakes:

Please do not ship lifters/parts to Perkins without first obtaining an RGA number. Parts received without prior authorization or without RGA markings will be discarded and credit will not be issued.

Orders that are placed without discussing warranty status will be treated as a typical order and will be billed accordingly. Credit will not be issued for warranty requests after the order is placed.

No warranty is allowed on lifters/parts not having a serial number.

Manufacturing Company

Perkins Return Policy:

If, within 30 days of receipt of the item(s), a customer would like to return an unused item(s), the customer may contact Perkins for a return authorization (RGA#). The item must be shipped within 2 weeks of the return authorization. The customer will pay the return freight and a 15% restocking fee on the return(s). The item must be in new / unused condition, and any damage or clean up required to restore the product to resalable condition will be charged to the customer.

Packages received without an RGA# on the packaging identifying who the product is from may be discarded or refused and credit may not be issued. Always make sure the RGA# is displayed on the box and on any included paperwork.

If Perkins shipped the wrong item(s), the incorrect item(s) may be returned within 30 days of receipt of the item by contacting Perkins for a return authorization (RGA#). The item(s) must be shipped within 2 weeks of the return authorization. Perkins will pay the return freight and waive the restocking fee.

If the return results in a net debit, the customer will be invoiced. If the return results in a net credit, the credit can be used against the replacement item(s) or a future purchase.

Special Notes:

Perkins does offer customized solutions and due to the customization of these items, Perkins cannot accept returns or refunds on anything custom ordered. This includes industrial units, cane lifters, and other items which have been specially fabricated to the customer's specifications. Unfortunately returns on these products cannot be accepted.

Perkins Manufacturing One-Year Limited Warranty

PERKINS MANUFACTURING COMPANY warrants its products to be free from defects in material and workmanship under normal use for a period of **one (1) year** from the date of delivery to the first purchaser.

Any claim under this warranty must be handled in accordance with PERKINS' warranty procedure.

This warranty is expressly limited to the repair or replacement in PERKINS' discretion of any component or part of any PERKINS product unit manufactured by PERKINS which is brought to PERKINS attention promptly after discovery and is proven to PERKINS' satisfaction to have been defective in material or workmanship.

This warranty shall not obligate PERKINS to bear the cost of labor or transportation charges in connection with the repair or replacement of defective parts, and it shall not apply to a product upon which repairs, or alterations have been made unless authorized in writing by PERKINS.

Any damage, wear & tear or improper use, substitution of parts not approved by PERKINS, modifications other than those done by PERKINS or as authorized in writing by PERKINS, or any alteration or repair by others in such a manner which, in PERKINS' judgment, materially and adversely affects the product shall void this warranty. Operation at an actuator cycle time of less than six seconds shall void this warranty. Wear items used for anti-friction purposes are not covered by this warranty.

Periodic maintenance is required in order to maintain warranty but is not covered by warranty. Please refer to the maintenance section of the service manual for instructions.

PERKINS makes no warranty of products manufactured by others and supplied by PERKINS, the same being subject to warranties, if any, of their respective manufacturers.

PERKINS shall not assume any liability for any incidental, consequential, direct, or indirect damage, loss or delay of any kind, including, but not limited to, the loss of profits, product or downtime.

PERKINS warrants any service parts it may sell for a period of ninety (90) day from the date of delivery for replacement only. The item being replaced must be returned to PERKINS for evaluation upon its request. The cost of labor to replace such part shall be the responsibility of the owner. PERKINS does not warrant any used parts.

PERKINS, whose policy is one of continuous improvement, reserves the right to improve its products through changes in design or materials as it may deem desirable without obligation to incorporate such changes in products of prior manufacture.

THE ABOVE WARRANTY SUPERCEDES AND IS IN LIEU OF ALL OTHER EXPRESS OR IMPLIED WARRANTIES INCLUDING, WITHOUT LIMITING, ANY IMPLIED WARRANTIES OF MERCHANTABILITY OR FITNESS FOR A PARTICULAR PURPOSE. NO EMPLOYEE OR ANY OTHER REPRESENTATIVE OF PERKINS IS AUTHORIZED TO CHANGE THIS WARRANTY IN ANY WAY OR TO GRANT ANY OTHER WARRANTY. THESE TERMS WILL BE CONSTRUED ACCORDING TO THE LAWS OF THE STATE OF ILLINOIS WITHOUT REGARD TO ITS CONFLICTS OF LAWS PROVISIONS. ALL ACTIONS OR PROCEEDINGS IN ANY WAY, MANNER OR RESPECT ARISING OUT OF OR RELATED TO THE GOODS WILL BE LITIGATED ONLY IN STATE OR FEDERAL COURTS, AS APPROPRIATE, LOCATED IN WILL COUNTY, ILLINOIS. BUYER CONSENTS AND SUBMITS TO JURISDICTION IN THE STATE OF ILLINOIS AND WAIVES ANY RIGHT TO TRANSFER THE VENUE OF ANY SUCH ACTION OR PROCEEDING.