



Installation & Operational Manual

Model WD6220

Hydraulic Cart Lifter

Protected by US Patents 6,929,411 & 6,503,045



Perkins Manufacturing Company
Creators of the TuckAway® Cart Lifter
www.perkinsmfg.com

800-882-5292

Revised:10/8/2020

Page 1 of 45

WD6220 Lifter Specifications

Cart Compatibility	ANSI Type B, US-Style two-bar carts having a bar to bar dimension of 14 ¾ - 15 ¼".
Typical Mounting Application	Rearloader
Tipper-Bar Compatible?	No.
Flow Rate Requirement	3.5 gpm
Cycle Time	6-8 seconds (up and down)
Recommended Pressure Setting*	1,550 psi at the pressure relief valve
Maximum System Pressure	3,000 psi
Weight Capacity**	350 lbs
Dump Angle	45 degrees from the horizon
Mounting Height (ground level to top of mounting plate)	38" up to 42".
Approximate Unit Weight (not counting packaging)	185 lbs
Hydraulic Package	Tap-In kits are sold separately
Warranty	3 years ***

Perkins regularly makes product improvements. Specifications are subject to change without notice.

* Actual pressure required to lift a load can vary.

** Do not lift more than the recommended amount printed on the cart by the cart manufacturer or damage or injury may result.

*** See Warranty page for full details of coverage



Overall Dimension

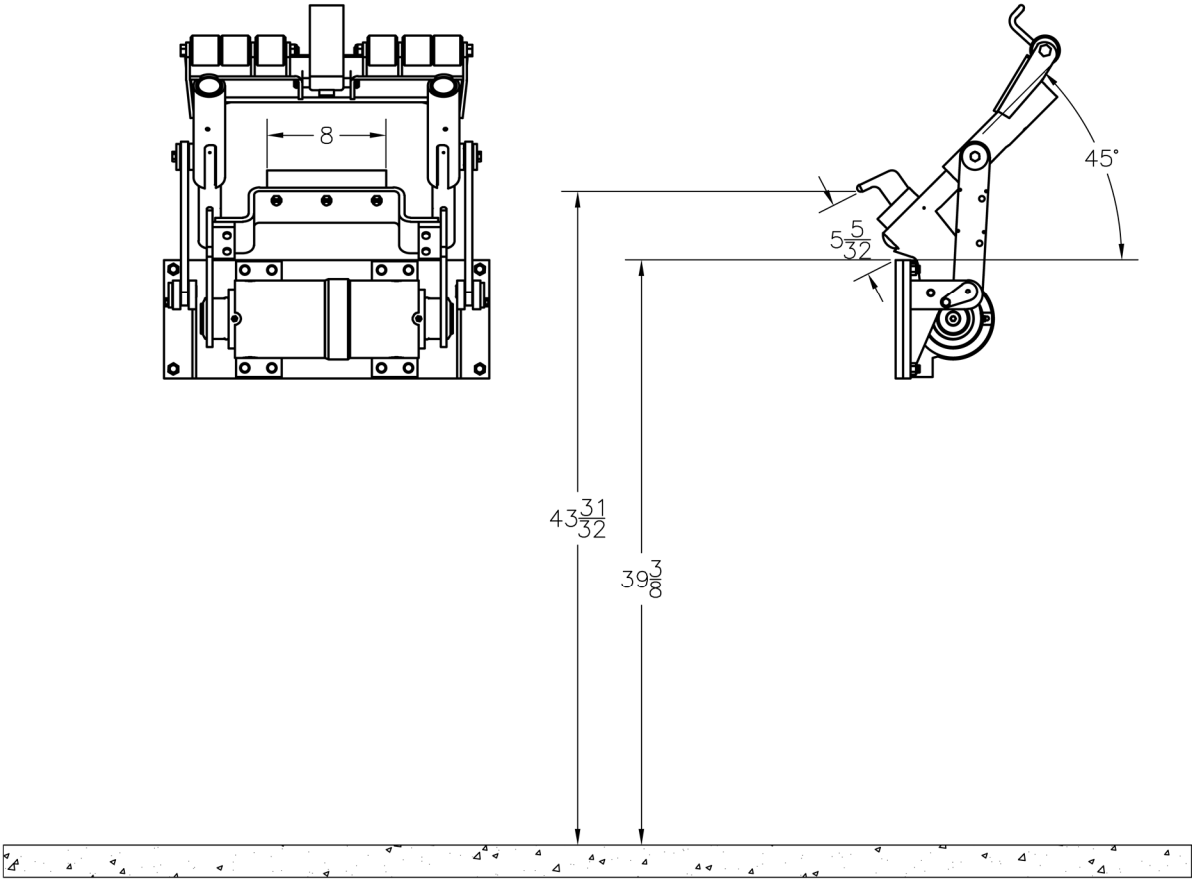
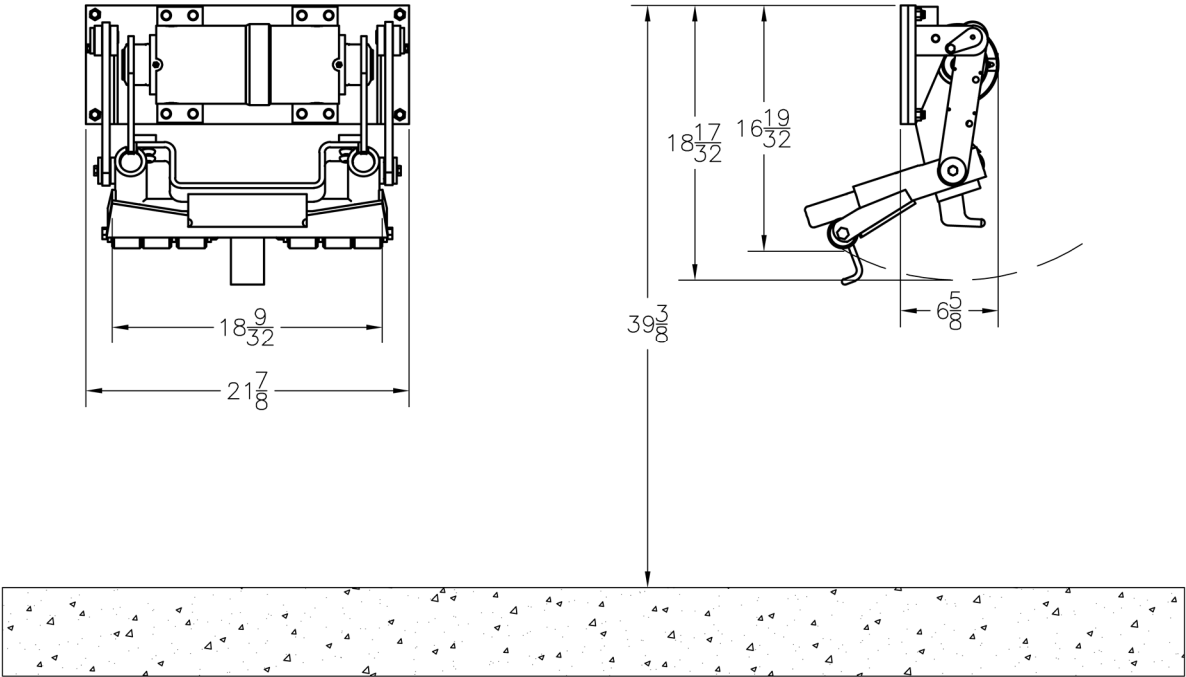

Perkins regularly makes product improvements. Dimensions are subject to change without notice.



Perkins Manufacturing Company
 Creators of the TuckAway® Cart Lifter
www.perkinsmfg.com

800-882-5292

Revised:10/8/2020
 Page 3 of 45

Glossary of Terms

Cart Types



ANSI Type B carts (US-Style two-bar carts) with a dimension of 14 ¾" - 15 ¼" bar to bar spacing.



ANSI Type C Carts (European-type) Using an upper lip for lifting. Height to ground varies with size of cart.



ANSI Type D Carts (Diamond-Type)



ANSI Type G Carts (Automated Collection) Having a rounded body ideal for gripper arms to clasp around.

Note: Some ANSI Type B carts are also Type G compatible, but some carts, particularly older designs, are not. This affects gripper-arm type of lifters that rely on grasping the cart around it's body. If using a gripper arm type of lifter, check your carts and see if they have rounded corners (look for approximately 6" radius). If so, they are likely ANSI Type G compatible.

Key Hydraulic Components



Diverter Valve



Hand Valve



PO Check Valve



50/50 Splitter



Double Diverter Valve



Adjustable Flow Control



Helical Rotary Actuator

Valves are sold separately or as part of a tap-in kit. The valves are shown for reference / identification purposes only. Your specific installation may require other equipment not shown.



Perkins Manufacturing Company
 Creators of the TuckAway® Cart Lifter
www.perkinsmfg.com

800-882-5292

Revised:10/8/2020

Page 4 of 45

Installation Safety

Please read this manual prior to installing, repairing or using this cart lifter.

- ✦ Installation of this equipment requires welding, painting, grinding, torching and working with high- pressure hydraulic systems. The appropriate safety equipment should be used at all times.
- ✦ Always follow OSHA specified lock-out procedures while working with a truck.
- ✦ Cart lifters weigh, on average, between 185 to 300 lbs. Do not lift the lifter onto the mounting plate by hand. Always use proper lifting equipment.
- ✦ Always use a chain or strap to secure the lifter in the upright position during the installation process. Unsecured lifters may fall suddenly causing injury.
- ✦ The truck to which the lifter is to be installed should be empty of waste. Torching and welding can ignite the contents of the truck and cause a fire.
- ✦ Do not weld on the truck unless a ground is in place and the battery is disconnected.
- ✦ Do not open/loosen any hydraulic lines unless the system is off and depressurized.
- ✦ Always double-check hydraulic fittings and hoses for tightness prior to reactivating the pump.
- ✦ Always relocate lights that need to be moved due to the position of the cart lifter to a clear and unobstructed area clearly visible to drivers.
- ✦ All painting of the truck/lifter after installation is complete should be done with proper ventilation and per local regulations. Do not paint over caution and warning labels.
- ✦ If there are any questions about the proper installation or use of the cart lifter not covered in the manual, it is recommended to call Perkins at 800-882-5292.



Installation Tips

Do not mount the lifter to a refuse body which is not already mounted to a chassis. Chassis heights can vary and this will affect the final installed height of the cart lifter.

Tack weld only until all positions and clearances are verified to work well for your application.

Always work on a smooth level surface with an empty truck.

Residential-Only Installation

A residential-only installation is when the cart lifter will be mounted to the truck and the truck will not be used for collecting commercial containers (such as 1 thru 10 yard containers). A residential-only installation is very straightforward and simple and very little customization required. Therefore, a residential-only installation may take only 4-6 hours.

The WD6220 is a TuckAway® Style Cart Lifter

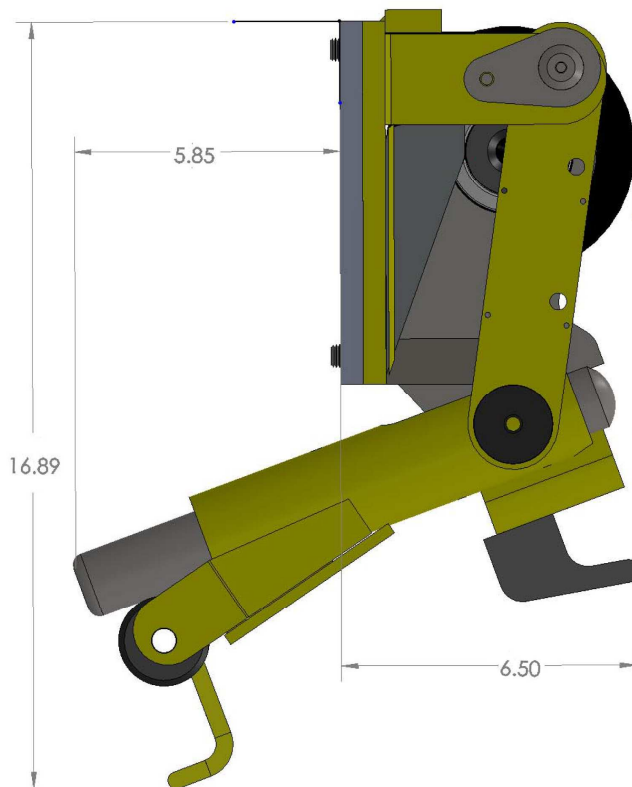

The first consideration when installing any TuckAway® style cart lifter is to make sure the unit has space to store under the load sill.

Some trucks have a hopper shape that does not accept a TuckAway style cart lifter, so it may be necessary to use a different cart lifter model in these cases.

Find the mounting height you will need to mount your cart lifter at as instructed on the following pages. Measure from this point down 13 ½" to check and see if the WD6220 TuckAway is the right model for this application.

If there is interference with a light panel, the panel may be trimmed at the customer's preference. Relocate lights if necessary.

If your truck does not have room to mount a WD6220 TuckAway®, call Perkins at 800-882-5292 for help selecting a different model.



Mark Your Centerlines

Begin by selecting whether the installation will be centered on the truck, or offset, or a double installation. Draw a centerline on the truck's loading sill.

A centered installation will place the lifter directly centered on the centerline of the truck.

An offset installation will place the lifter 17 ½" from the center of the truck, (usually to the curb side) as shown in the picture at right.

A double installation will place a lifter 17 ½" to the left and 17 ½" to the right of the truck's centerline.



A typical offset installation.

Determine the Mounting Height

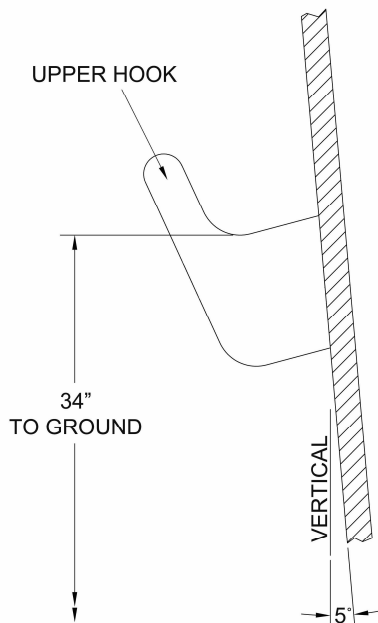

Upper hook mounting height

The mounting height is critical to the proper function of any cart lifter. The ideal location for the upper hook is 34" off the ground, when the lifter is positioned so that the faceplate is 5 degrees tilted back from vertical as shown in the diagram at left.

It is important that the packer body be mounted to a chassis, and the truck is empty and parked on a smooth and level surface when this mounting height is determined.

A cart lifter which has been positioned too low may kick carts away before successfully engaging them.

A cart lifter which is mounted too high will make it difficult for the operator to latch the cart at all, causing the operator to have to lift the cart onto the latch.

A good mounting height will make latching carts effortless with no lifting or holding the cart in place.



Positioning the Mounting Plate

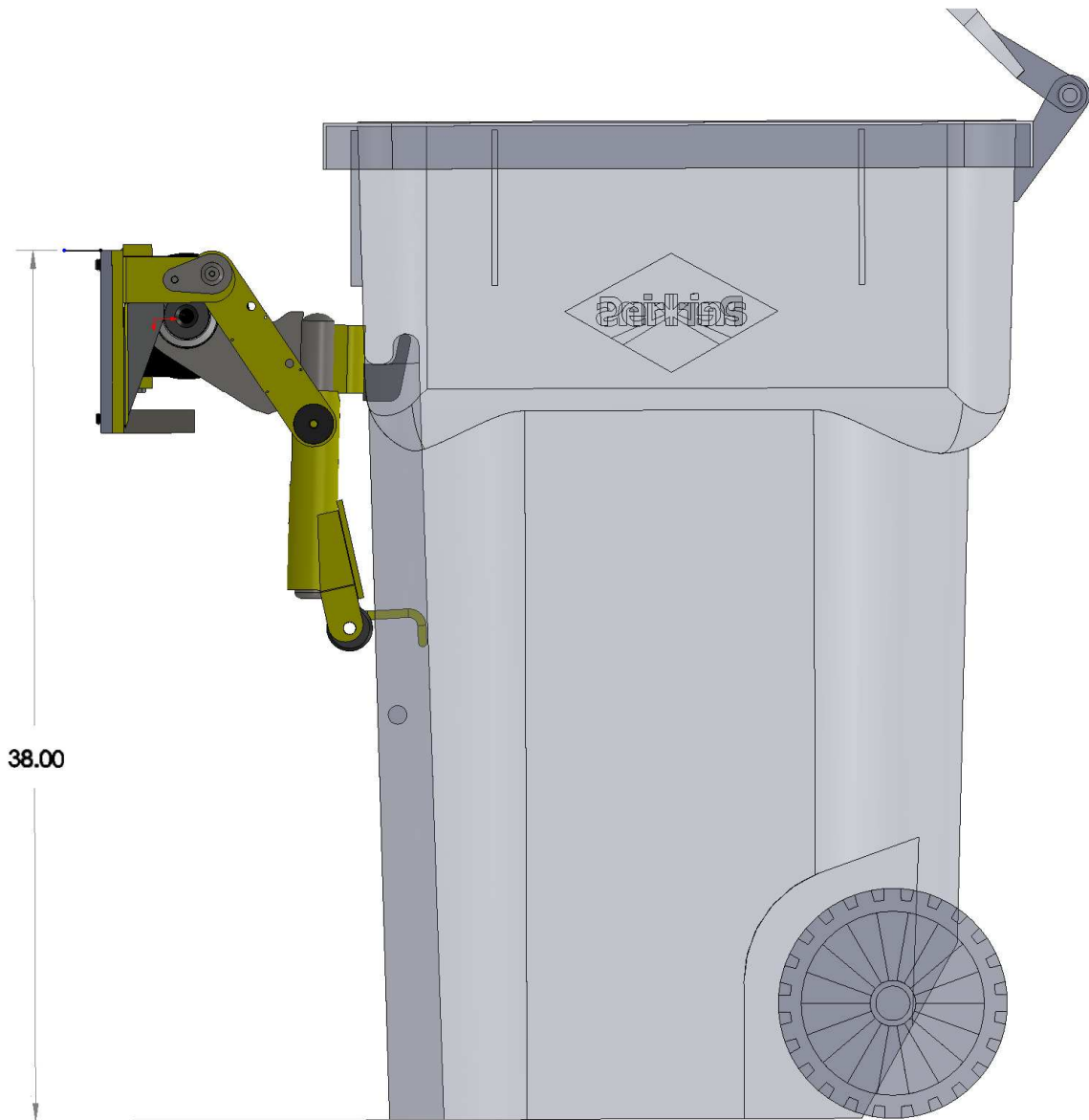

** The mounting plate may be positioned as low as 38" and as high as 43", as needed. The mounting plate itself should be vertical and level.*



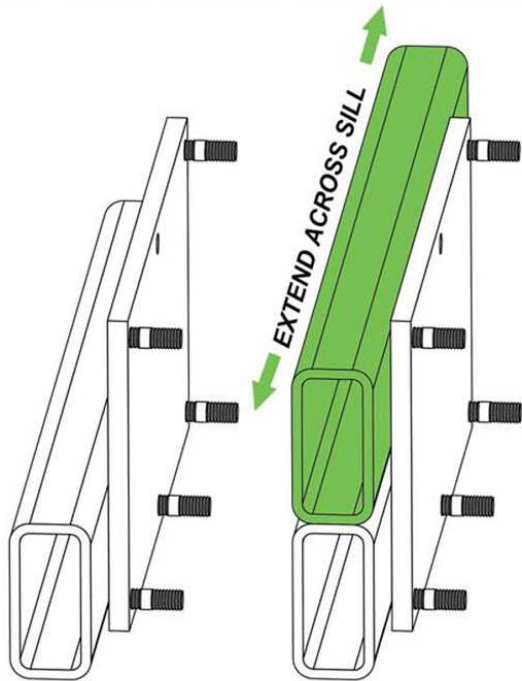

The Rear Mounting Plate of all lifters must be completely supported around all edges of the plate.

Unsupported plates will lead to premature lifter failure.

In the example at left, the mounting plate is well above the original height of the sill. A steel tube of appropriate size is cut and placed on top of the sill, extending it up and meeting with the top edge of the mounting plate. This additional piece would extend across the entire length of the hopper sill. Weld fully, leaving no portion of the mounting plate hanging above or below the original sill without support

In the example at right, the mounting plate is shown to be slightly above (or slightly below) the sill edge. In this case, add a strip of material and endcaps to the exposed mounting plate rear and weld fully.

Installations will vary from truck to truck. Custom cut pieces will likely be required to properly support the mounting plate.

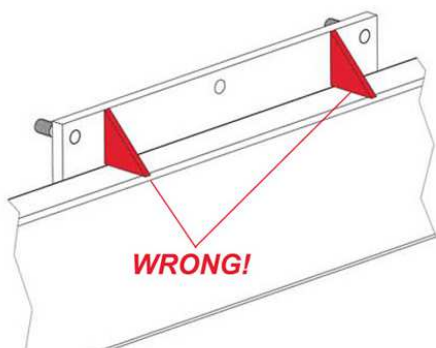
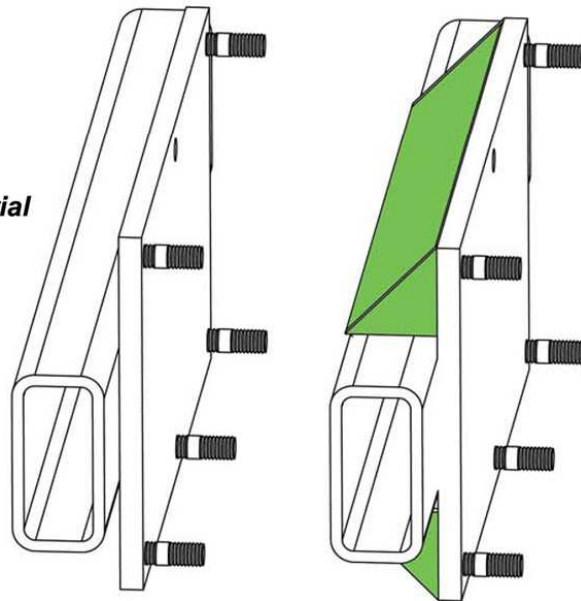

The drawing at left is an example of inadequate support. The gussets will not help add rigidity to the mounting plate and the mounting plate will deform over time, leading to premature lifter failure. Never leave any portion of the mounting plate hanging without proper backing material.



Residential-Only Installation Example



A typical example of a curb-offset positioned, residential-only installation. Note that the load sill has been extended to match the top of the mounting plate with a piece of structural tubing running the length of the load sill. The mounting plate is fully supported.

After the cart lifter and supports are tack welded in place, move the cart lifter by hand up and down carefully, making sure there are no interferences. Double check the hook height to the ground. If everything appears satisfactory, the lifter's mounting plate and supports may be welded fully.

The mechanical portion of the installation is complete.



Perkins Manufacturing Company
Creators of the TuckAway® Cart Lifter
www.perkinsmfg.com

800-882-5292

Revised:10/8/2020

Page 10 of 45

Mixed Commerical & Residential Installation

When performing a commercial installation, the same procedure of the residential installation must be followed with these additional steps:

Recess The Cart Lifter

When a truck is provided with commercial container locks, the OEM will usually add an extended bumper over the original load sill.

To mount a cart lifter to a truck like this, you must recess the cart lifter by cutting a notch in the extended load sill.

Cut a notch that will leave a 2" gap on either side of the lifter.

Do not cut into the original load sill. The original load sill is a structural member of the tailgate and must not be severed or the structural integrity of the tailgate will be compromised, leading to distortion and failure.

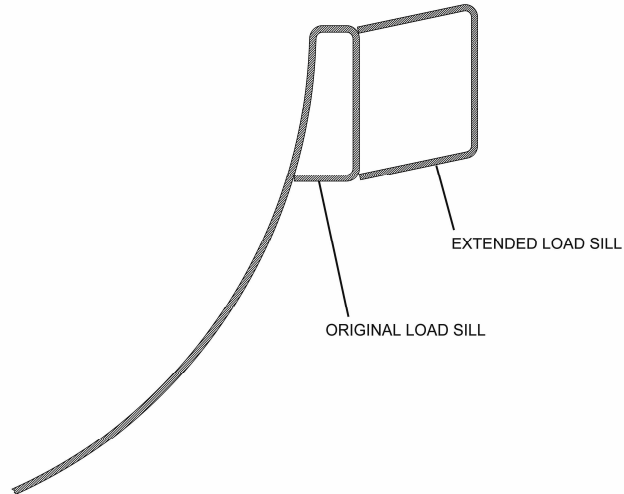

TOP VIEW OF TRUCK LOAD SILL

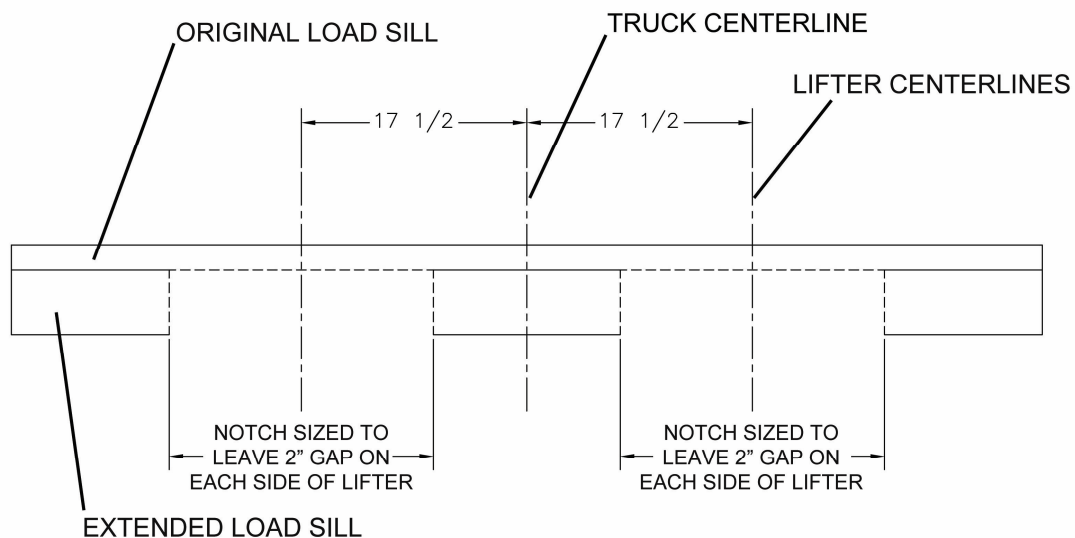

Note: Be careful not to cut into the original load sill or else the structural integrity of the tailgate can be compromised. It may be necessary to add custom structure reinforcements where the lifter is to be mounted.



Add the Sill Extension (Bumper kit)

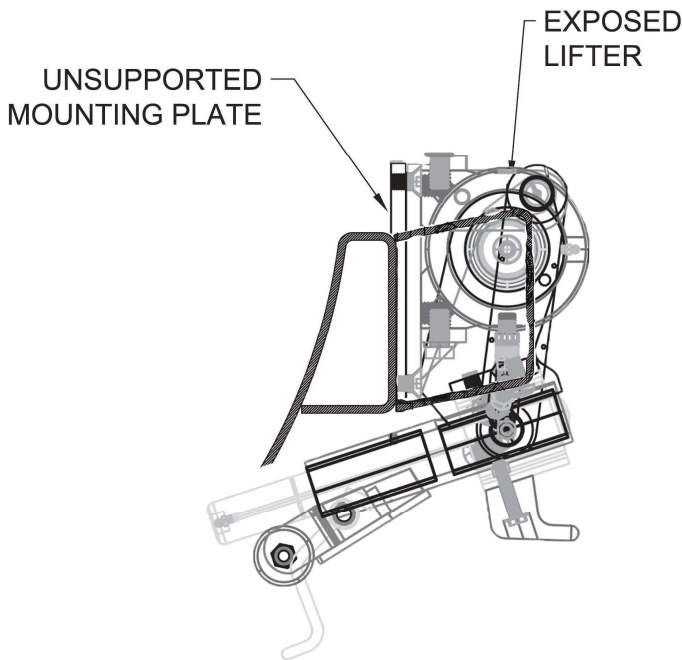

With the notches in the sill extension cut out, cap off the exposed ends and mount the mounting plate, using the correct mounting height as previously described.

It may be necessary to add customized pieces to bolster the support of the mounting plate on top or below the plate.

At this point, the lifter may stick out above or beyond the extension sill. That is normal.

Note: The size and shape of the bumper extension can vary depending on your fabrication preferences. Perkins does offer pre-made bumper extension kits, sold separately:

CA1084 – single lifter, offset to the right

CA1085 – single lifter, center mounted

CA1086 – double lifter installation

Now we add the rest of the supporting structure.

Like in the residential-only install, it is necessary to bring the load sill up to match to the top of the mounting plate and/or top of the bumper extension.

Contact with commercial containers can easily crush the cart lifter. To protect it, install a bumper extension over the OEM-supplied sill extension. The bumper should be sized and positioned so that contact with a commercial container is not possible.

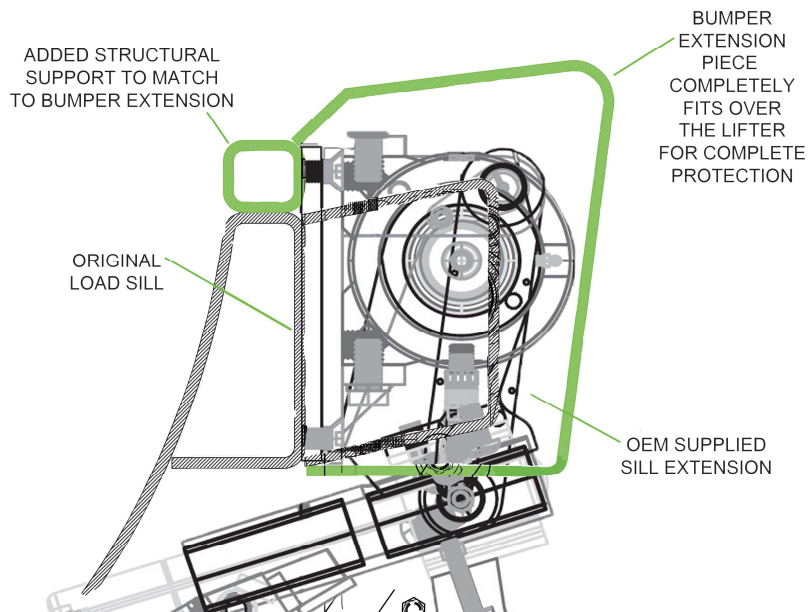

Moving the Container Locks

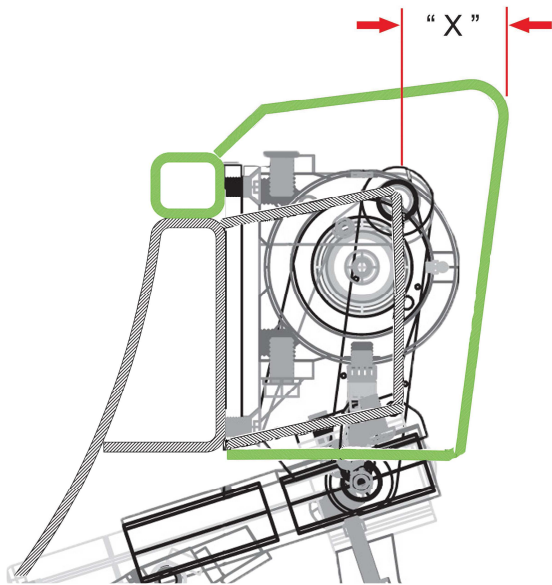

At this point, the bumper extension is now sticking out past the OEM-supplied sill extension by "X" inches. This dimension might typically be about 3" or 4".

Measure this dimension. The distance the extension has shifted out is the distance the container locks must be extended.

Carefully torch the elephant ear and container locks right off the truck.

Reposition the container locks and elephant ears back on the truck at the same height and spacing, but shifted back to the rear of the truck.

The shift distance "X" is equal to the amount the bumper extensions went past the OEM-supplied extension sill "X".

Add filler material as a spacer to take up the gap created by shifting the locks.

It may be necessary to reconstruct the container lock backing bars to make them have a smaller gap.

Customized pieces of steel are used throughout this step and are not provided by Perkins.

Prior to fully welding, make sure a commercial container will properly lock up to the container locks in their new position.

Double check that a commercial container cannot make contact with the lifter. If everything is satisfactory, weld fully.

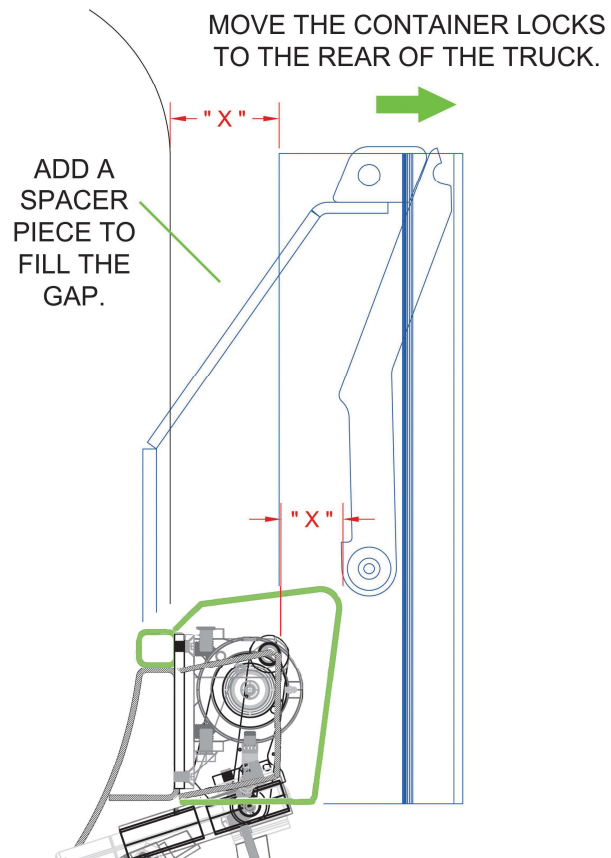

Mixed Commercial & Residential Installation Example



Note the Bumper Extension fully protects the cart lifter from contact with the commercial container. The elephant ears and container locks have been shifted back and material added. The reverse lights have been relocated in this installation so they would not be obscured by the lifter placement.



Perkins Manufacturing Company
Creators of the TuckAway® Cart Lifter
www.perkinsmfg.com

800-882-5292

Revised:10/8/2020

Page 14 of 45

Hydraulic Oil

The most important component of any hydraulic system is the oil. Perkins cart lifters use standard seal materials and should therefore be compatible to most grades of hydraulic oils, operating in typical weather conditions for most of North America. However, the condition of the oil is an important consideration that should not be overlooked.

Hydraulic oil may be dirty, contaminated, lost its viscosity, burned up, or have too high a concentration of absorbed water and/or air. While these things are unlikely to cause an immediate performance issue with your cart lifter, these issues can lead to premature wear and tear in the longer term.

Perkins would like to take this opportunity to remind you to check the quality of your hydraulic oil periodically and make sure it meets your standards. Oil that is maintained in good condition will help your equipment last longer.

Non-Perkins Controls

Some customers with new trucks may choose to use hydraulic controls provided by the OEM. As long as the GPM and pressure settings used match the specifications required, then the lifter should operate fine. Perkins cart lifters do not require special Perkins valves to operate.

In other cases, a Perkins cart lifter may be replacing a competitive lifter for which controls are already installed. Again, Perkins cart lifters should work just fine with competitive equipment, as long as the GPM and pressure settings are adjusted within the specified ranges.

Lifter Speed

The cycle time of the lifter is very important for safe operation. Perkins suggests a complete cycle time of 6-8 seconds (3-4 seconds up and 3-4 seconds down). Faster cycle times may be dangerous. Running a lifter too fast can damage the cart, or make a cart break loose off the lifter and fall, resulting in damage and/or injury.

The speed of the cart lifter is determined by the rate of oil (gpm) going to the unit. Typical lifters with a 27k actuator will require approximately 3.5 gpm in order to meet this speed. A gauge is recommended but not needed to determine proper lifter speed. Counting the cycle time using a stop watch is adequate to determine proper flow rate. Running a lifter too fast will void the warranty.

Weight Capacity

The maximum amount of weight that can be lifted is limited by the pressure relief valve. The settings must be determined with a pressure gauge. The WD6220 requires 1650 psi to lift a 400 lb load. Place a pressure gauge after the hand valve and run the actuator until it stops, continue activating the handle and note the pressure on the gauge. Adjust the relief valve according to the manufacturer's instructions.



Perkins Hydraulic Installation

(Sold Separately)

Locate the Hand Valve Assembly

A suitable location for the hand valve assembly should be found on the side of the truck. Its placement should not interfere with any existing truck components. The handle should be a comfortable distance from the ground (typically about 48" high) so that repeated ergonomics is easy to use and safe.

The Perkins hand valve assembly comes with a mounting bracket which may be welded directly to the side of the truck. Typically, the hand valve's handle will point to the back of the truck and the ports A & B which feed the lifter will be pointing to the ground.

This position should allow the operator holding the handle to still be within arm's reach of the cart that is being lifted. This keeps the steps back and forth to a minimum for best efficiency.

Tack-weld the valve bracket in place temporarily until all the hoses have been routed.



Note the hoses feeding the lifter are pointing straight down. The hoses leading back to the pressure supply and tank and pointing towards the front of the truck and all hoses are neatly routed for a clean look and best hose protection.



Locate and Connect the Diverter Valve

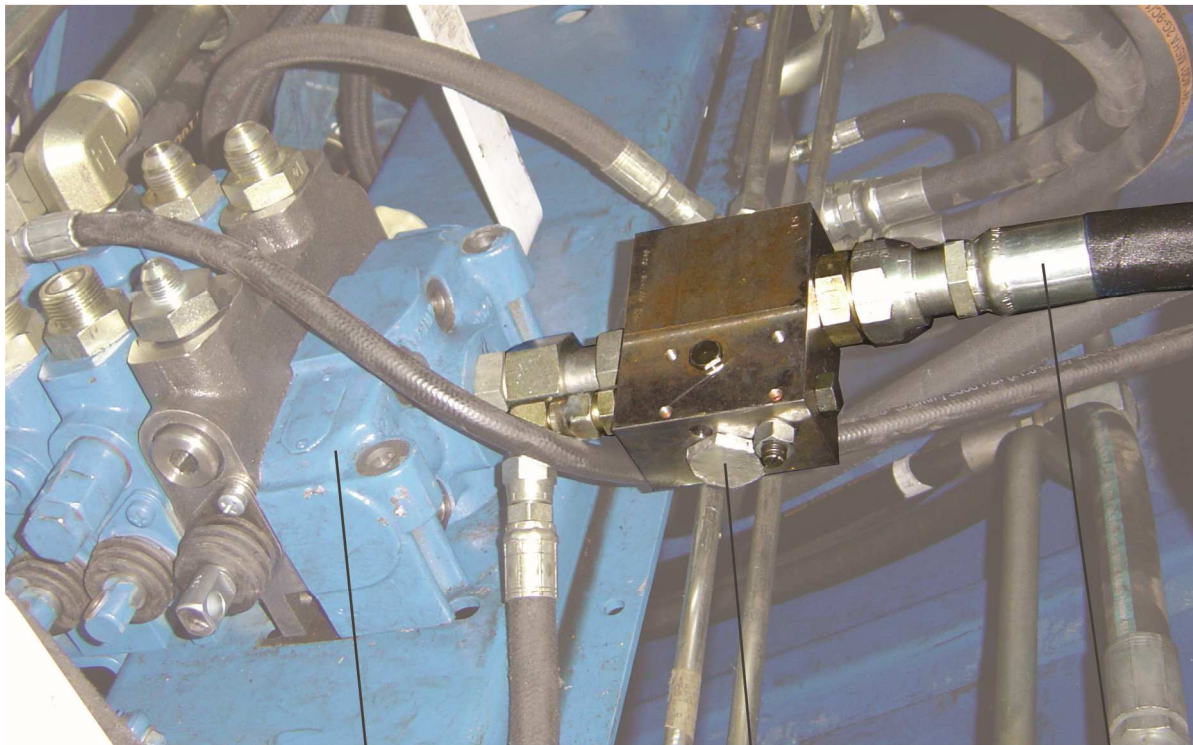

**PACKER BLADE
CONTROL VALVE**

DIVERTER VALVE

PRESSURE LINE

The diverter valve is designed to accept full system flow, continuously divert a portion of that flow to the lifter(s), and pass the remaining flow on to the packer control valve. The amount of flow that is diverted is adjustable, so the same valve that feeds one lifter can also be adjusted to feed two lifters.

Adding the Perkins diverter valve to your system will slow down your packer cycle by several seconds, whether you are actively using the lifters or not. However, this is usually an acceptable tradeoff, since the Perkins diverter valve doesn't generate much backpressure or heat, and it allows you to use the packer and the lifters simultaneously.

With the system off and depressurized, find the pressure line that feeds the packer valve and disconnect it. Connect this pressure line to the "IN" port of the Perkins diverter valve. Connect the "OUT" port of the diverter valve back to the packer control valve where the pressure line originally was.

The fittings to do this will vary from truck to truck. The Perkins Tap-in Kit generally gives you the required fittings, but due to the wide variety of trucks, changes made by the OEM, as well as the possibility of other aftermarket parts, especially on used trucks, the fittings you need to make these connections may not be included in your kit and will have to be purchased separately.



The Perkins Diverter Valve

Ordinarily, the diverter valve's port "P" will feed the lifter.

But, if you have two lifters, then you will use the Perkins Double Diverter Valve.

It's the same valve, except port "P" is plugged, and a 50/50 splitter valve is mounted on top.

In this case, ports "P1" and "P2" will feed the lifters an equal amount of flow each.

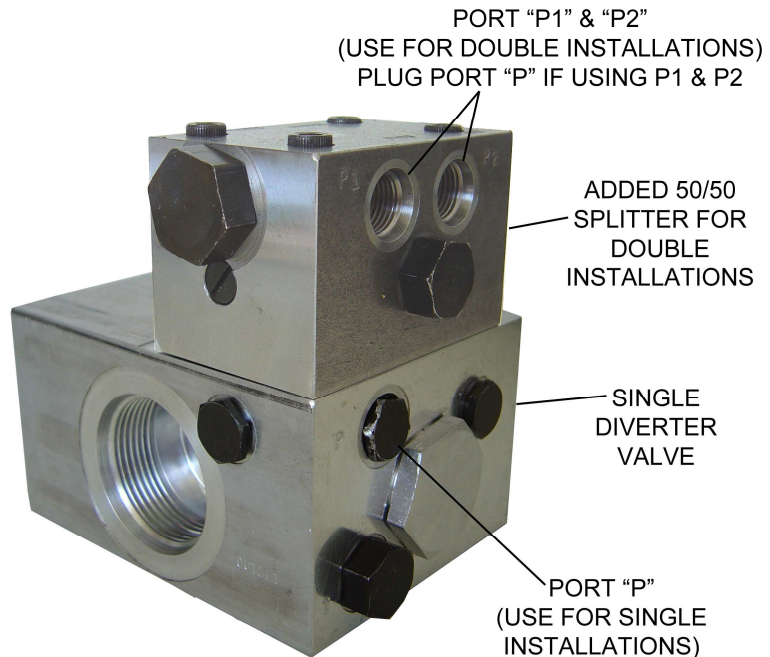

Making the Hose Connections

All the primary valves are now in place for a typical installation.

The tap-in kit would have come with 2 short hoses and 2 long hoses (single installation) or 4 short and 4 long for double installation.

Connect one short hose from the lifter's left side to the hand valve port "A".

Connect another short hose from the lifter's right side to hand valve port "B".

Note: If the handle's operation is not as desired, you may switch the hoses to reverse the handle's operation

Connect one long hose from the hand valve's "IN" port to the diverter valve's "P" port. (or if performing a dual installation, to port "P1" or "P2")

Connect the last long hose from the hand valve's "OUT" port to a tank line. *

Note: See photo of tank line connection on following page for more details.

Make sure all the hoses have been routed neatly. The hoses must be protected from rubbing or pinching.

If performing a double installation, repeat this process for the second lifter.



Tapping into the Tank Line

There are two ways to run the oil back to tank. Perkins does not suggest allowing the return oil to get pushed back into the packer control valve, because this generates back pressure and heat.

Recommended Method: Locate the return line coming off the packer control valve and find a suitable large fitting as shown in the photo below. Remove this fitting and drill and tap into it to fit an adapter (or tee for a double installation) to allow the oil to flow back into the return line.

Be sure to clean the fitting of metal shavings before returning it to the system.

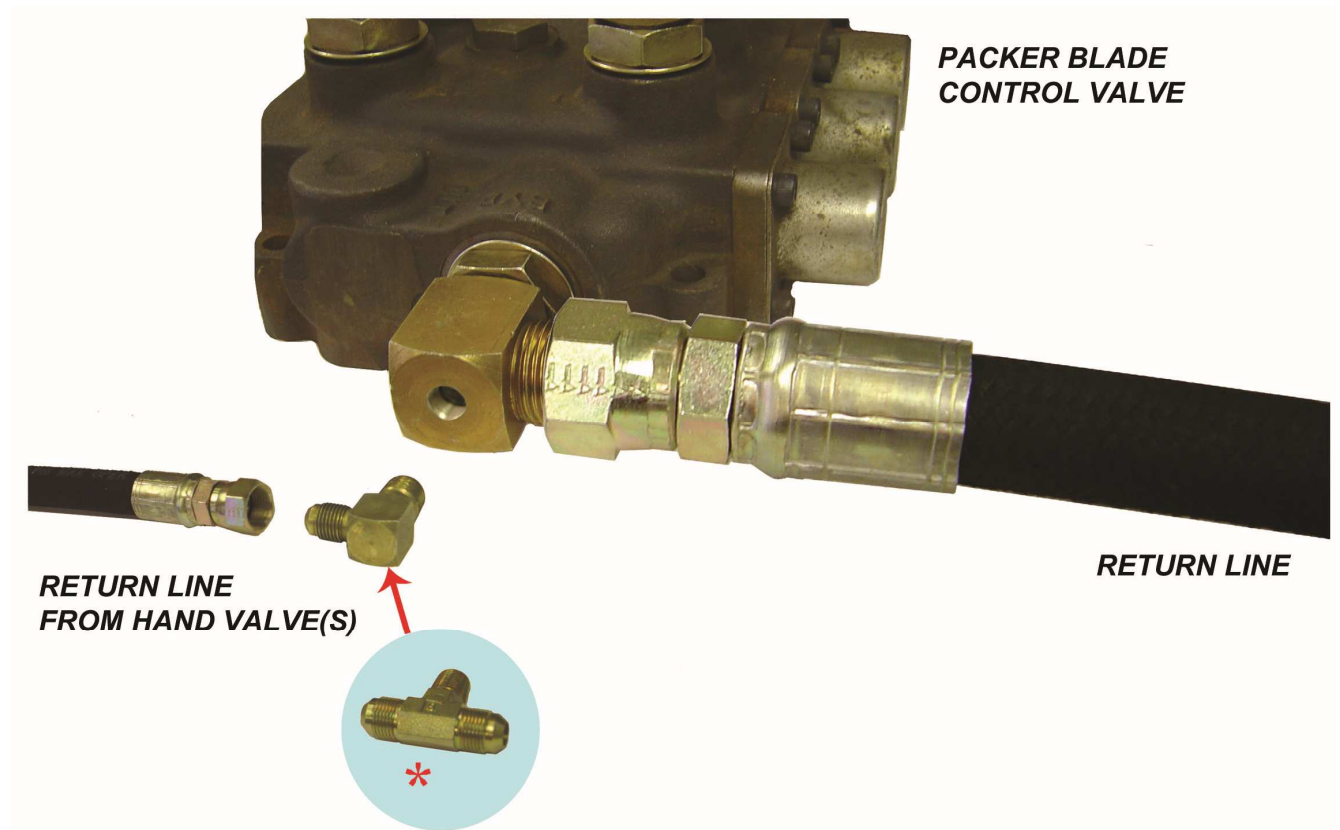

Alternative Method: On some trucks, it is not possible to tap into a return line fitting. In some instances, everything is hard-piped and there are no fittings to tap into. If this is the case, the return lines may be feed into the "T" port of the Perkins Diverter Valve. This tends to create some backpressure in the system, but otherwise does work.



Adjusting the Perkins Hydraulics

Adjusting the Speed

Single Diverter: D63237s

Double Diverter: D63411s

This valve's adjustment controls the flow going to the lifter. The flow controls the speed of the lifter.

A typical 27k rotary lifter requires 3.5 gpm to achieve a 6-8 second cycle time.

To adjust, turn off the system and loosen the locking nut. Turn the adjustment screw clockwise all the way in. This will stop flow to the lifter completely. From this position, make counter-clockwise adjustments ½ turn at a time. When the correct position is found, tighten the locking nut to hold the adjustment in place.

CAUTION ADJUST THIS VALVE WITH THE HYDRAULIC PUMP OFF OR VALVE DAMAGE COULD OCCUR

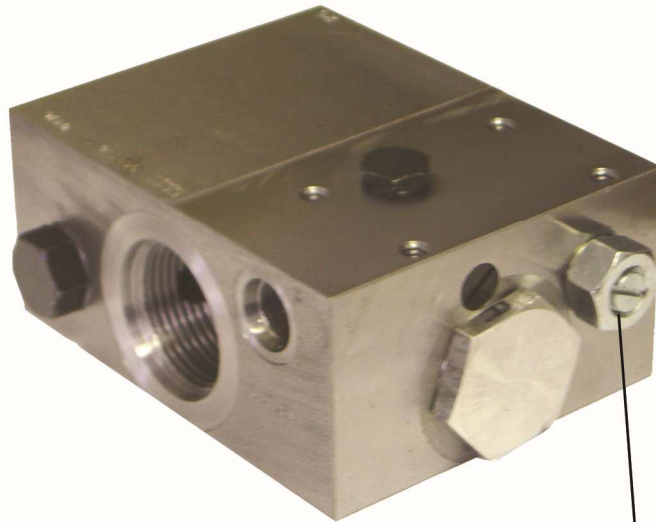

ADJUSTMENT SCREW

Replacement Parts:

D63477 – Seal Kit

D63565 – Adjustment Screw

To convert a Single Diverter to a Double:
D63236 – 50/50 Splitter (comes with mounting hardware).

Troubleshooting the Diverter Valve

This diverter valve does not affect lifting power / weight capacity!

Only check this valve if your lifter stops moving, or moves to fast or too slow.

Maintaining the Diverter Valve

The valve requires no periodic maintenance.

If a problem is thought to exist in the diverter valve, turn the system off and check the cartridge by unscrewing either of the large caps from the ends and removing the cartridge. The cartridge may then be cleaned and inspected. Flush the valve out to remove any contaminants, return the cartridge and reinstall.



Adjusting the Lifting Capacity

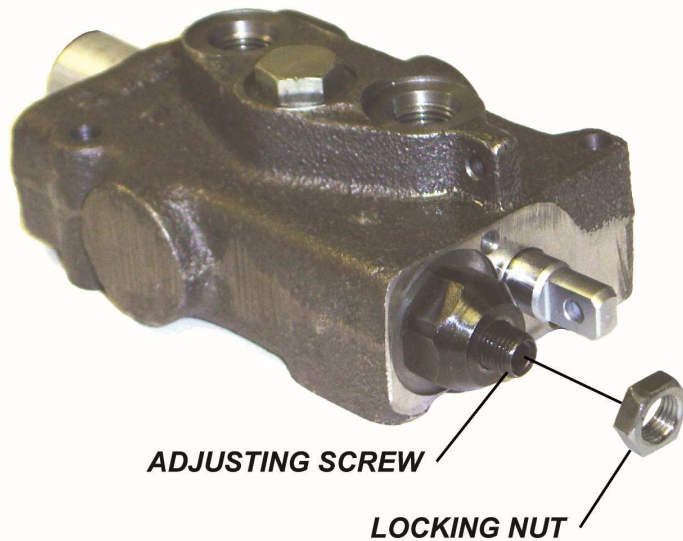

Note: The setting for the WD6220 is approximately 1650 psi to lift 400 lbs.

Hand Valve: D63228 (valve only)

This valve directs the flow to the lifter to make it move up or down. It features a “deadman” stop. Release the handle and the lifter should stop moving.

The valve has a built-in pressure relief valve. To increase the lifting capacity, loosen the locking nut and turn the adjusting screw clockwise. It is recommended to use a pressure gauge to achieve the right setting. Raise the lifter until it stops and continue to pull the handle. Note the pressure on the gauge and adjust the screw accordingly.

When the pressure is correct, retighten the locking nut.

Replacement Parts:

D63127 – Seal Kit

D63192 – Spring Kit

D63672 – Cartridge Kit

Troubleshooting the Hand Valve

This valve does not affect lifter speed!

Only adjust this valve if the lifter won't pick-up the desired weight, or if a chattering noise is heard.

Don't be fooled! Containers full of water, concrete, rocks, dirt, wet grass or other materials can easily weigh far more than the capacity of the lifter. Just because the lifter doesn't pick up that heavy cart, doesn't mean the lifter needs adjustment! If there is doubt, try weighing the container in question.

Maintaining the Hand Valve

This valve requires no periodic maintenance.

If a problem is traced to the hand valve, turn the system off and remove the cartridge. Clean and inspect the cartridge. Make sure the handle returns to center on its own. If it doesn't, it may need a spring kit.

There are usually multiple relief valves within the same system. They must be set at least 100 psi apart from each other or they will “chatter”. Adjusting one valve to be set differently than another should eliminate the problem. Example: Pump relief valve 2000 psi, packer relief valve 1900 psi, lifter relief valve 1650 psi.



Maintaining the PO Check Valve

PO Check Valve: D63580

The valve locks the oil from escaping unless the hand control is activated. This locks equipment in position and prevents drifting when equipment is idle. It also acts as a safety, in the event of a broken hose, the valve stops the movement of the equipment.

This valve is not adjustable.

This valve requires no periodic maintenance.

If a problem is traced back to the PO check, turn off the system and remove the cartridge. Clean and inspect for damage. Replace cartridge if needed, flush the valve, rebuild and install.



Maintaining the Adjustable Flow Control

Adjustable Flow Control Valve: D63575

The valve is located on the left-hand side port of the rotary actuator. Its purpose is to restrict oil coming out of the actuator when the lifter is moving back down. By restricting the oil, the lifter is prevented from “getting ahead” of the oil and slamming into the ground.

This valve only works in one direction, so adjusting it does not affect the speed of the upwards direction.

The valve has a small arrow stamped into its body. The arrow should point away from the actuator.

If the lifter comes down too quickly, try turning this valve in clockwise ¼ turn at a time until the down direction is smooth and under control.



Servicing the Perkins HKS Rotary Actuator

Perkins HKS 27k Actuator: D73060HKS

Common Parts: Seal Kit: D73060HKS-1 Actuator Shaft: D73060HKS-2 Bearing Kit D73060HKS-3

The manual for the actuator is provided separately and free of charge. It contains detailed instructions for rebuilding, based on a complete tear-down. Also, within the manual is a complete parts listing. To receive a copy of the actuator manual, simply call Perkins at 800-882-5292.

Flushing the Actuator

Because the oil displacement of the actuator is nearly equal to the displacement of the hoses, the oil inside the actuator does not fully dispel to the system and get filtered with each use. Only a percentage of the oil dispels. Because of this, it is possible to have build-up of particles over time which can lead to premature wear, especially in dirty oil conditions. Perkins recommends flushing the oil in the actuator to the system to allow for complete filtration once every 6 months. This will help ensure the actuator has a very long lifespan.

To flush the oil, turn off / depressurize the system and connect a hose from one bleed port to the other. Tighten the fittings restart the pump. Run the hand valve back and forth several times, holding the handle down for about a minute each time. This ensures any particles have completely exited the actuator.

**BYPASS HOSE
USING THE #4
BLEED PORTS**



Bleeding air from the Actuator

Air does not usually get trapped inside the actuator, but it does happen on occasion, particularly with initial installations. For this reason, the actuator has #4 bleed ports located atop it. Cracking the plug loose slightly will allow trapped air to escape.

Perkins recommends this be performed only as necessary. Lifter motion that is very erratic is usually a sign of trapped air. The lifter should be run several times up and down first, as this usually clears any trapped air without having to use the bleed ports.

Make sure the bleed ports are fully tightened when complete.

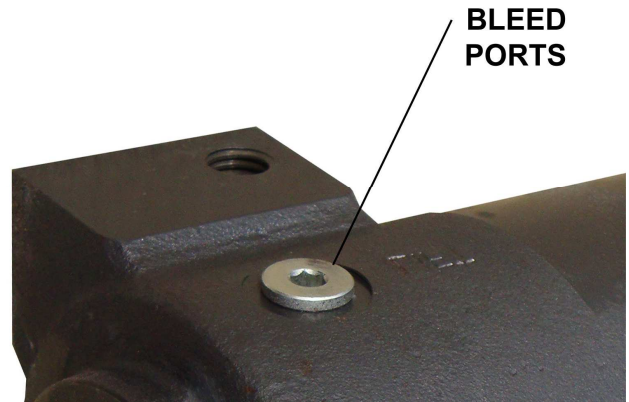

Perkins Single Lifter Hydraulics Schematic

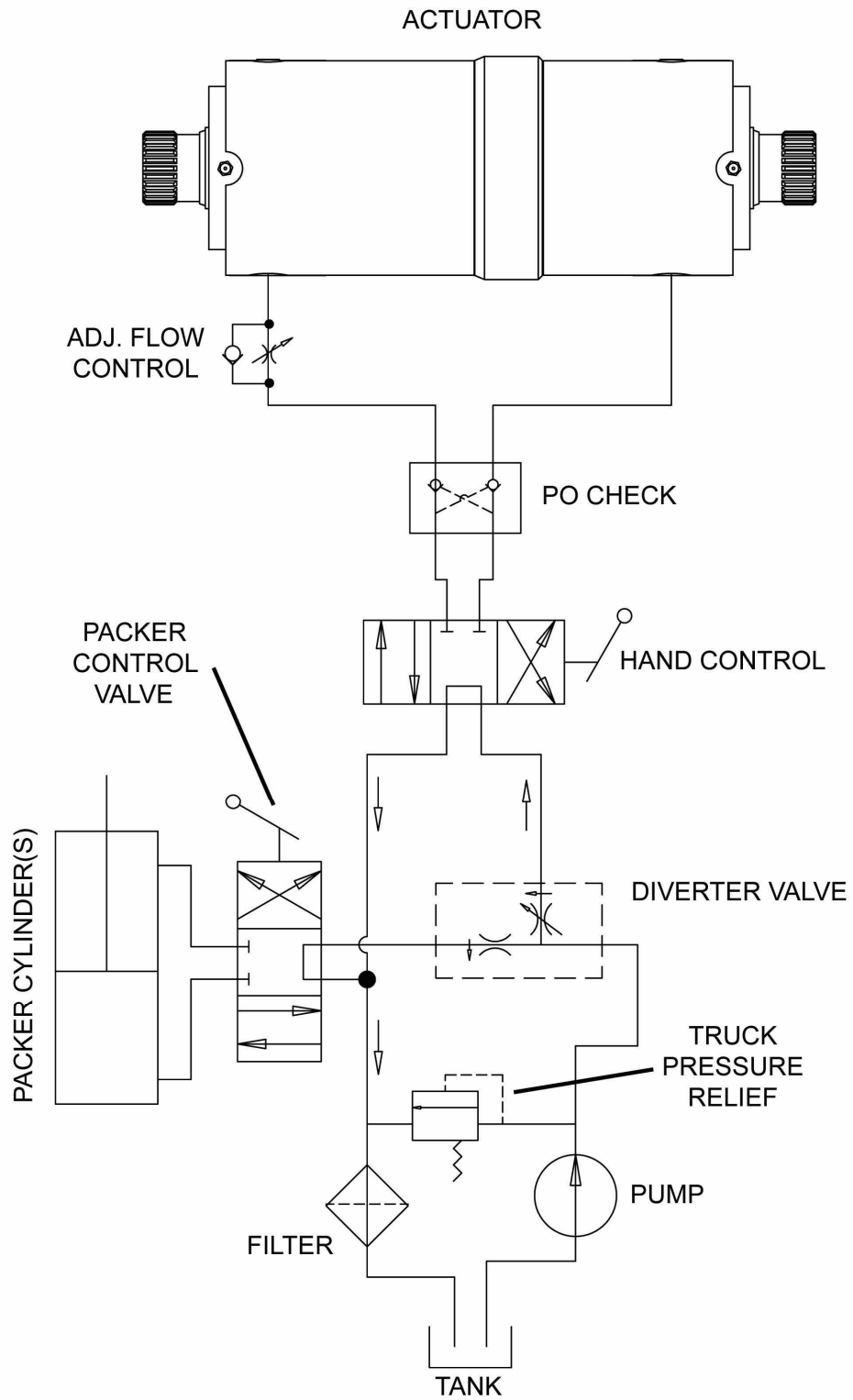

Perkins Double Lifter Hydraulics Schematic

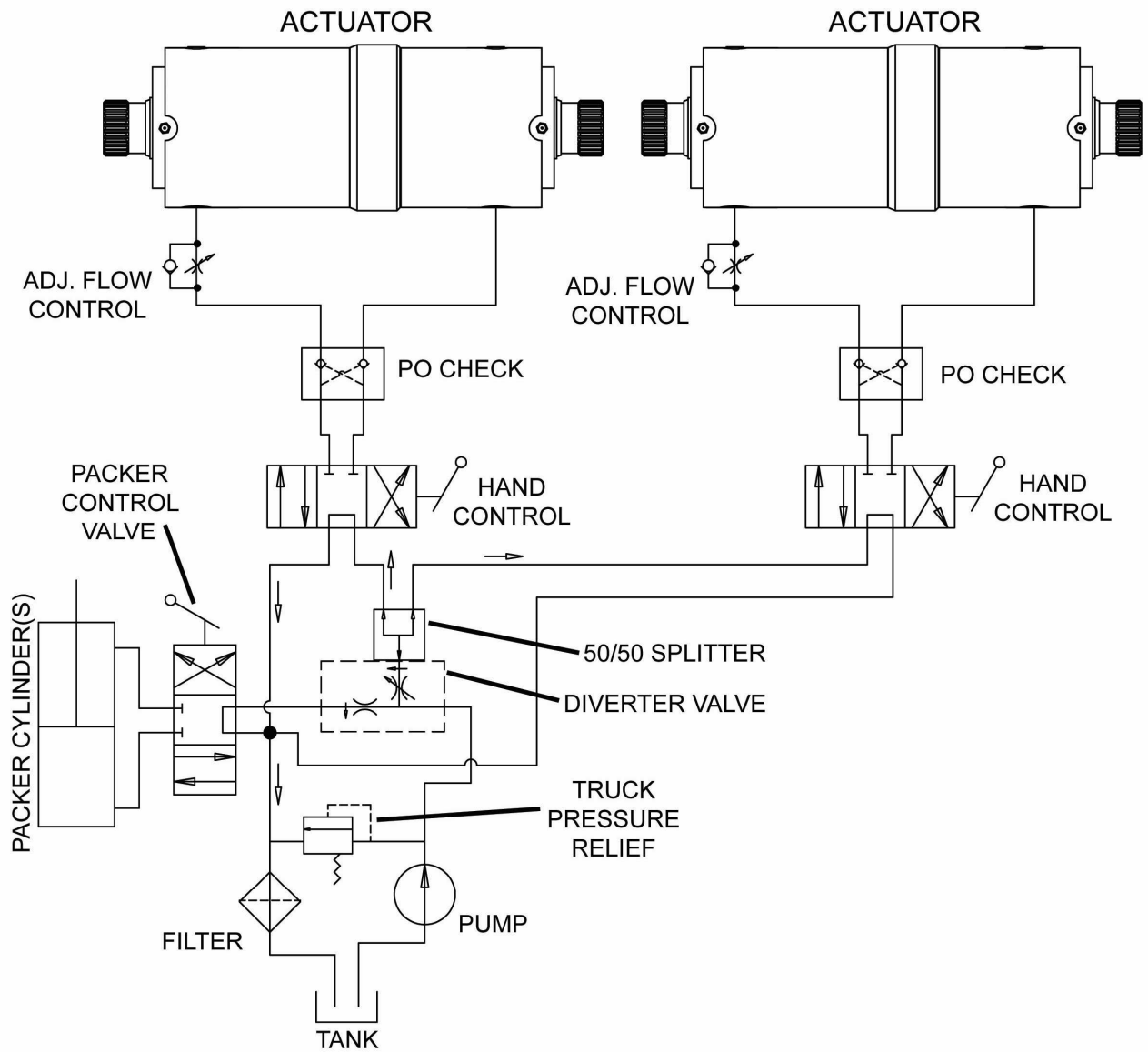

Operating the Lifter

Operating Instructions

The recommended cycle is 3-4 seconds to travel up and 3-4 seconds to travel down. This cycle time is based on the safe and smooth movement that the plastic cart can be swung about at without risking damage to the cart or injury to the operator. Therefore, operating the lifter faster than this time will void the warranty.

It is recommended that the lifter be visually inspected on a daily basis to ensure that there is nothing obviously in need of repair. Broken or missing parts/hardware should be attended to immediately to avoid risk of further damage to the lifter, damage to the cart, or injury to the operator. Operating a cart lifter that is not properly maintained is hazardous.

Step 1: Bring the TuckAway lifter out of the storage position and into the pick-up position by pulling up on the hand valve handle until the faceplate is just shy of vertical, to facilitate easy cart engagement.

Step 2: Roll a loaded cart to the lifter and position the upper bar of the cart on the upper saddle of the lifter or in a position where the lifter will engage the bar once it starts its motion. (It is not necessary to lift the cart onto the upper saddle)

Step 3: Look and make sure no one is in the area of the lifter or cart, then operate the hand valve by pulling up on the handle. The lifter will rotate and engage the cart and raise it to 45 degrees above the horizon.

Safety Note: The hand valve operates like a deadman switch. Releasing the handle at any time will stop motion of the lifter. Normal operation may be resumed by operating the handle again.

Step 4: Lower the cart by reversing the hand valve handle (pushing down), until the cart is safely returned to the ground and the lifter has disengaged the cart.

Step 5: Remove the empty cart and repeat the process as needed.



Safe Operating Tips

Always follow your company's safety policy during the use of this lifter, including use of proper clothing/ personal protective gear, reflective clothing, etc. Remember, you are operating the lifter on a public road/alley among moving traffic. Always be aware of your surroundings and watch for cars and pedestrians.

Do not lift anything with the lifter other than ANSI approved carts which are in good condition. Non-approved carts may not lock properly, causing them to fall from the lifter, which can cause damage or injury and will void the warranty.

Do not use the lifter for any purpose other than lifting a cart. Lifters are not meant as steps, they are not to be used to help lift a commercial container, or used to crush/breakdown an item. Doing so can cause serious damage or injury and will void the warranty.

Speeding up the lifter beyond the recommended cycle time of 6-8 seconds and/or adjusting the relief valve to pick up weights heavier than 400 lbs can lead to damage or injury and will void the warranty.

Do not operate the lifter unless the area around it is clear of personnel. This means do not touch the lifter while it is in operation and do not stand or sit under/near the lifter while it is moving. Lifters have pinch points which can cause serious injury. Stay clear at all times.

TuckAway lifters can hang very low to the ground at certain points of their lift cycle. It is the operator's responsibility to move the lifter to a safe position while going down the road, such as putting the lifter all the way up or fully into the storage position. Lifters left hanging low risk bottoming out on the street, which will cause serious lifter damage. Damage caused by bottoming out is not covered by warranty.

Lifters of all kinds can be struck by utility poles, walls, other vehicles, backed into earthen hills, etc. It is the operator's responsibility to position the cart lifter in a safe position prior to coming close to any other foreign object. If the lifter is damaged by collision, the damage will not be covered by warranty.

If the lifter is installed in such a way that the lifter or cart can make contact with the packer blade, then it is critical to pay attention and make sure the lifter is not operated when the packer blade is down or coming down.

If the truck is equipped to dump commercial containers, the lifter must be stored all the way down prior to engaging the commercial container or the cart lifter may be crushed by the container. This damage is not covered by warranty.



Other Adjustments

Make sure all hardware is firmly tightened. If any hardware loosens they may be affixed with Blue Loc-tite type 242 thread locker.

Perkins uses anti-sieze lubrication on the shafts of the actuator when applying the driver bearing hubs. This typically does not wash away and helps in reducing corrosion. This makes removing the driver bearing hubs off the splines easier in the future. When rebuilding a lifter, reapply a fresh coating of anti-sieze on the splines.

There is a wide variety of carts, some of which do not meet ANSI standards. Customers may experience engagement issues with some particular brands of carts and in circumstances like these, spacers can be added behind the upper saddle or behind the lower stop to extend them out from the faceplate. This helps certain brands/sizes of carts to lock to the lifter better. If you experience any difficulties with the cart type you have, please call Perkins at 800-882-5292 to discuss the problem and Perkins will advise the best solution to meet your needs.



Washing

A simple and quick power-wash will remove filth and grime from the lifter's critical components, making them last longer and making inspection for damages.

Lubrication

Proper greasing of the lifter is important. Check the lifters weekly and grease as necessary any pivot or slide points that do not move smoothly. Some newer machines have fiber glide bearings that do not require grease. Your local weather conditions will vary the frequency of your necessary greasing.



Bearings

The lifter should move freely, but snugly. Any play or looseness indicates bearing wear. Bearings that are worn or scarred should be replaced immediately.

Breakaway Feature

If your lifter has a breakaway feature, there may be a shear bolt on driver arm. Make sure the bolt is in place before use daily.

Lifter Components

Use weekly greasing as a time to perform a spot check of the parts on the lifter, ensuring nothing is bent or showing fatigue. A damaged lifter may still dump carts, but it may damage them too. Protect your carts by keeping your lifters in good condition.

Hydraulic Components

Inspect all hoses and replace any that are worn or frayed. Look for signs of leaks and tighten the appropriate fittings. Lifters that drift when not in use may need a new seal kit for the actuator, or hand valve. Don't forget to bleed the air after any hydraulic work.



Lifter operation is erratic, lifter does not move smoothly

When the lifter does not move smoothly, there is typically air in the system. This is usually an issue after the initial installation or a recent repair where the hydraulic lines may have been opened. Bleed air out of the system by loosening a fitting very slightly and running the hand valve to create flow. Excess air should bleed out of the opening in the fitting. Retighten when complete done.

In rare instances, the flow may be too low. This would also be noticeable if the lifter was also very slow. Try adjusting the diverter valve to increase the flow.

Another possibility is the adjustable flow control, D63575 not functioning properly. Check the arrow printed on the valve body. The valve should be installed so the arrow points away from the actuator. Adjust, clean, or replace the adjustable flow control valve as needed.

Cart lifter will not pick up the weight

The cart may be overweight. If the cart is obviously very heavy and hard to move, try removing a few items from the top to lighten the load.

The hand valve relief pressure setting may be set too low. Check and adjust the pressure using a pressure gage. Note the pressure being delivered and adjust accordingly.

If adjusting the hand valve's relief does not bring the pressure up to where it should be, then the truck's relief pressure setting may be set too low. Try adjusting the truck's relief valve (see manufacturer's instructions on how to do this for your vehicle)

In cases of older equipment, the hand valve may be in need of replacement or repair.

If all pressures are set properly and the hand valve works, then the actuator may have internal leakage. Test for internal leakage by running the lifter all the way up and dead-head the lifter up. Note the pressure gage and see that the pressure stays constant as the hand valve is held depressed. If the pressure falls, you may have internal leakage and the actuator should be repaired/rebuilt with new seals.



Lifter operates slowly

Check the flow adjustment on the diverter valve. Use a flow meter to make sure each lifter receives approximately 3.5 gpm. Adjust diverter as needed following instructions in the manual.

Engine idle may be too low to provide adequate flow. Following the manufacturer's instructions, adjust the engine idle. Remember increasing engine idle will increase fuel consumption.

The hand valve may be faulty. Check, clean and/or replace as needed.

The truck's pump may be faulty, unable to deliver the desired flow. Contact your truck manufacturer.

In rare instances, debris within the oil may be clogging the diverter valve. Check and clean the valve as needed.

Lifter operates too fast

Check diverter valve adjustment screw. Adjust in to lower the flow delivered to the lifters.

Engine idle speed may be too high. Adjust per the manufacturer instructions.

Diverter valve is leaking oil

Worn or Damaged seals within the diverter will cause external leaking. Rebuild the valve using D63477 divert valve spring kit.

Hand valve lever sticks, does not return to center

A worn or broken spring on the spool will cause the handle to fail to return to center. This is dangerous, since this means the deadman stop feature is not working. Check and replace the spring with part number D63192.

If the spring is not the problem, check and clean the hand valve of any rust/corrosion and debris in or around the spool or the external parts.

On new installations, this is the result of having the pressure and tank lines reversed. Check and make sure that the pressure line goes to the "IN" port and the tank line goes to the "OUT" port.



Hand valve is leaking oil

This is typically caused by worn or damaged seals. Install new seals with part number D63217

In some cases, the spool itself is worn. If so, replace the hand valve.

Unable to achieve 1950 psi at the hand valve

The truck's pressure setting may be too low. Adjust the truck pressure according to the manufacturer's instructions.

If pressure cannot be increased further, it may be necessary to install a speed up switch which will rev the engine higher during peak need to deliver the desired pressure. Note that speed up switches will increase fuel consumption.

Unable to achieve over 1400 psi

The truck pressure is too low. If adjustments do not help, the pump may be bad or underpowered. Contact your truck manufacturer.

Lifter breaks the lower bars of carts

First, make sure there is no damage to the lifter. Replace damaged components as needed.

Check adjustment of plunger assembly and threaded rod assembly. Check function of plunger. Adjust as needed.

On new installations, check the mounting height. It is common for brand new lifters to break lower bars if the lifter is installed too low. Remove the lifter and remount at the correct height.

Lifter breaks upper bar of carts

The upper bar of the cart is typically broken when the cart is lifted while it is excessively loaded, or while the lifter is operated too quickly. Adjust the speed of the lifter to bring the cycle time to 6-8 seconds. Make sure the pressure is set no higher than 1950 psi.

Make sure the lifter is not damaged. Bent or broken lifter parts can contribute to cart damage.



Lifter drops carts

A common problem is the lower latch is not adjusted correctly or the latch is damaged or unable to move freely. Check, clean and grease the parts as necessary to achieve free motion of the latch and appropriate latch timing.

Make sure the upper hook is not damaged and make sure the lower stop is in place. Some customers have been known to remove the lower stop, but this leads to dropping carts and latch damage.

Carts which are damaged or have missing lower bars will obviously not latch properly and should be repaired or replaced.

Some carts do not meet ANSI standards. Measure the problem cart and see that the bar to bar spacing is within 14 ½ - 15 ¼.

Lifter slams down to the ground or comes down too quickly

On the way down, the lifter can get ahead of the oil and free fall. Check that the adjustable flow control is mounted to the left side of the actuator, with the arrow pointed away from the actuator, and that the valve is adjusted properly. Try ¼ turn adjustments until the lifter returns to ground level smoothly.

Lifter drifts out of position when not in use

Make sure the PO Check valve is installed. If it is and the lifter still drifts, remove the PO check and remove and clean the cartridge. If the valve is damaged, replace it.

If the problem does not seem to be the PO check, the hand valve may have internal leakage. Replace the hand valve seals and/or spool as needed.

If the problem persists, then the actuator may be leaking internally. Check for internal leakage by running the lifter up and holding the hand valve while reading a pressure gage. If the pressure falls, then the actuator is leaking internally and should be rebuilt with a new seal kit.

Lifter is in good condition, latch is adjusted, but lifter still breaks carts

In this case, the lifter is most likely being operated too fast, or the carts are overweight. Excessively hard shaking of the carts by the operators can also lead to cart damage. Train your operators to operate the lifters properly.



Making a Warranty Claim

For complete warranty coverage details, please see the warranty page at the end of this manual.

If you suspect that failure of the lifter to operate is due to a defect, please take a moment to locate the serial number of your lifter.

Warranty cannot be honored on lifters or individual pieces unless a serial number is provided. Since the tag is frequently lost, damaged, or painted over, it is a good idea to note the serial number in this manual at the time of installation.

At right is an example of the serial number plate. It will be stamped with a model number and serial number.

Once you have the number, please call Perkins Manufacturing at 800-882-5292 for additional instructions.

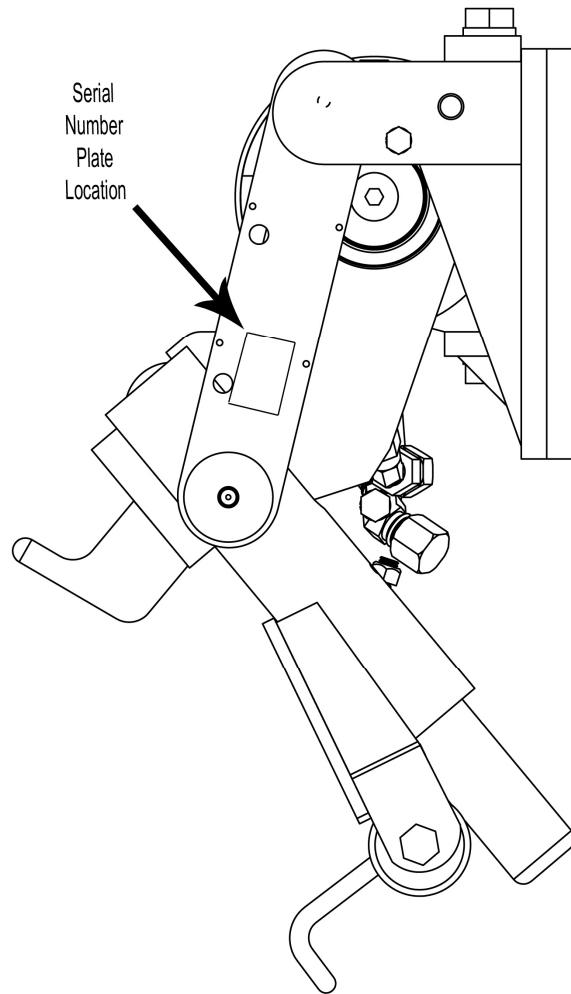

Exploded Parts View

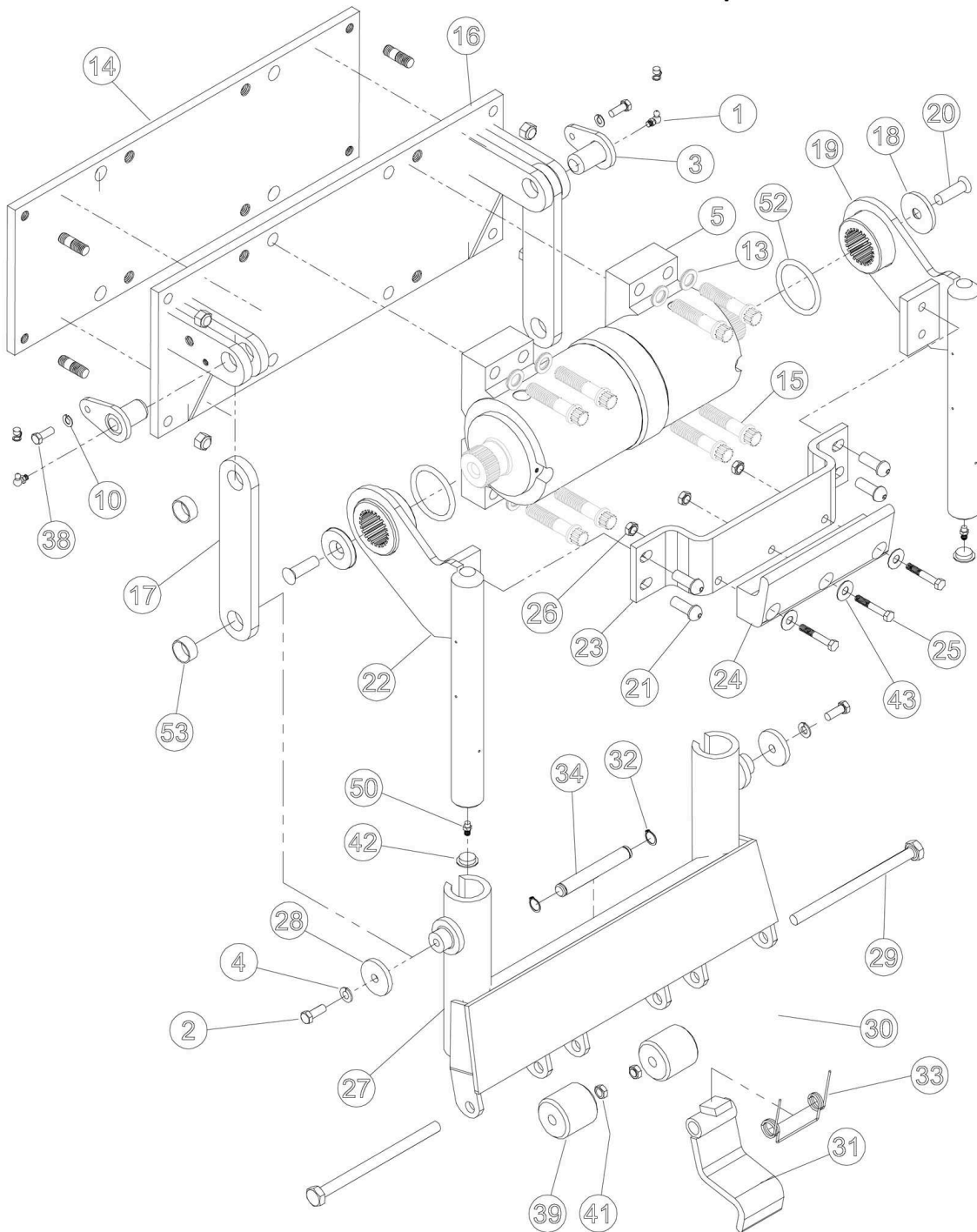

1	D72028	90 deg. Grease Fitting ¼-28	2
2	D62043	Bolt HHCS 3/8-16 X ¾	2
3	D77130	Pin Weldment	2
4	D62106	3/8" Split Lockwasher	2
5	D72830HKS	WIDEFOOT 27k Helical Rotary Actuator HKS	1
6	D63074	Fitting STR. #6MT - #6FT	1
7	D63581	Fitting Elbow 45 DEG. #6MT - #6FT	2
8	D63562	Hydraulic Cap #8 JIC	2
9	D63569	Elbow 45 DEG. #6MO - #6MO	1



10	D62053	Split Lockwasher 5/16 DIA.	2
11	D63431	Reducer #6FT - #8MT	1
12	D63663	Fitting Elbow 45 DEG. #6MO - #8MT	1
13	D38040	NORDLOCK 5/8" LOCKWASHER	8
14	D77754	Rear Mounting Plate	1
15	D77784	12 PT Flange Bolt 5/8-11 X 2 3/4	2
16	D77753	Mounting Plate Weldment	1
17	D77756	Idler Arm	2
18	D73008	Actuator Hub Retaining Disc	2
19	D77750	Arm Weldment Right Hand	1
20	D62006	Bolt FHCS ½-13 X 1 ¼	2
21	D72021	Bolt BHCS ½-13 X 1 ¼	4
22	D77749	Arm Weldment Left Hand	1
23	D76609	Upper Hook Bracket	1
24	D65255P	UHMW Plastic Upper Hook	1
25	D62085	Bolt HHCS 3/16-18 X 1 ¾	3
26	D62080	Lock Nut 3/8-16	3
27	D76616	Slide Weldment	1
28	D76779	Retaining Disc - Idler Arms	2
29	D62487	Bolt ½-13 X 7 ½ HH	2
30	N/A		
31	D76672	Lower Latch Weldment	1
32	D62001	5/8" Lock Nut	2
33	D76677	Spring-Lower Latch	1
34	D79344	Threaded Rod – Latch Pivot	1
35	D63575	Adjustable Flow Control Valve	1
36	D63491	Serial Number Plate (Not Shown)	1
37	D72009	Drive Screw #6 X 3/8 (Not Shown)	4
38	D62113	Bolt HHCS 5/16-18 X ¾	2
39	D69226A	Small Roller – Black UHMW	6
40	D63029	Plastic Zerk Caps (Not Shown)	2
41	D72030	½-13 Thin Nylon Lock Nut	2
42	D72107	Plastic Pin Driver Cap	2
43	D62060	3/8 Flat Washer X 13/16" OD	3
44	D62474	Label – Large Caution (Not Shown)	1
45	D72106	Nylon Set Screw	2
46	D72113	Label – New Perkins Logo (Not Shown)	1
47	D72114	Label – English Caution (Not Shown)	1
48	D72115	Label – Spanish Caution (Not Shown)	1
49	D62458	5/8" DIA Split Lock Washer	4
50	D62014	1/8" STR Grease Zerk	2
51	D72086	Bolt FHCS ½-13 X 1	5
52	D63238-9	External Hub Seal	2
53	D72108	Bearing RBC 1" DIA X ½" Wide	4



27k HKS (Current) Actuator Parts Guide

The housing pieces 001-1 & 006-1 and the piston 003-2 are not replacable due to the need to mate the parts at the factory for the correct fit. Seals are sold only in kit form which includes all the seals for one actuator. Bearings/Wear strips are sold only in kit form, which includes all bearings and wear strips for one actuator. These actuators will be stamped with a SN# starting with #S55

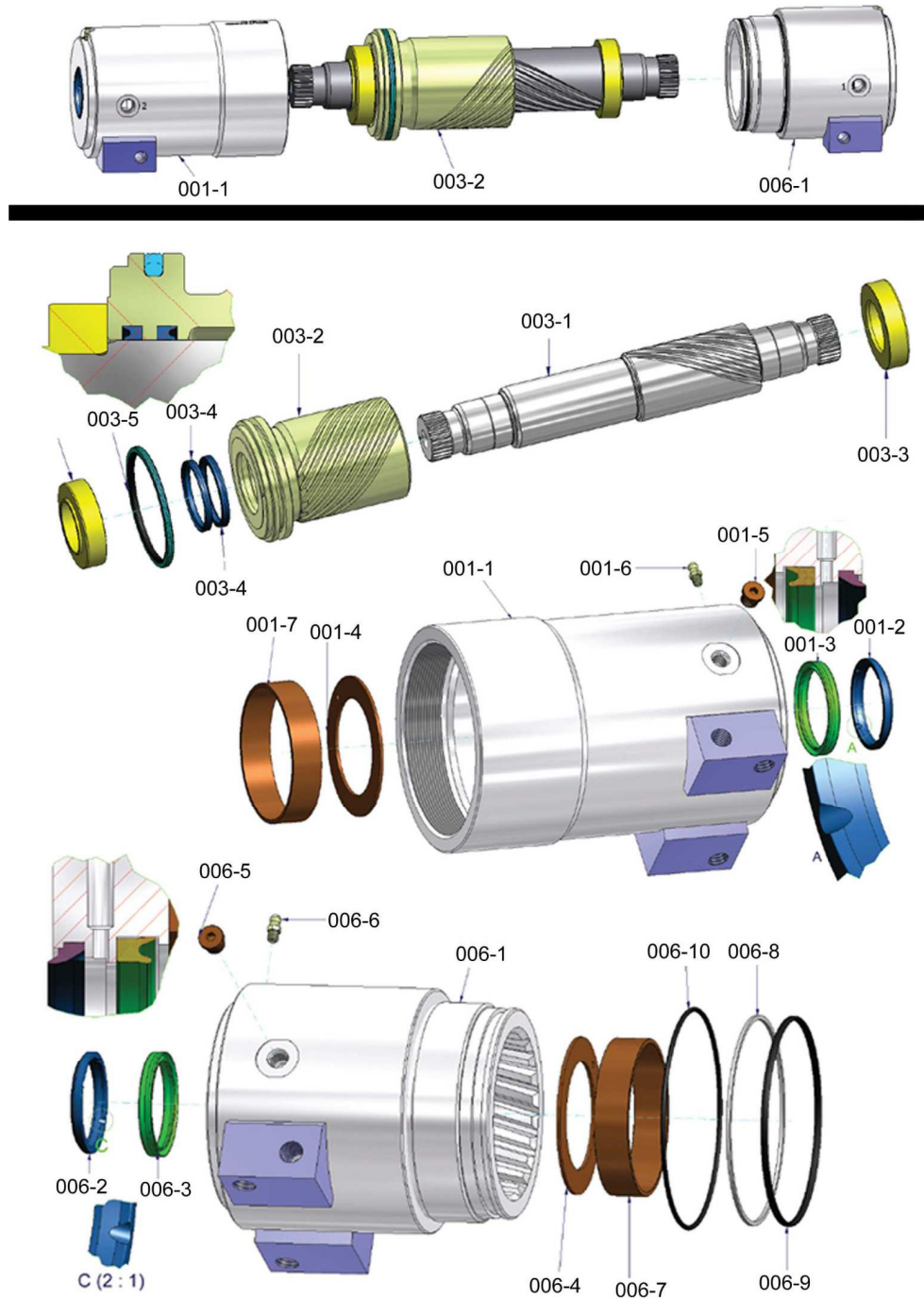

Telling the Actuators Apart

Perkins Actuator Differences

HKS Actuator (current)



HKS Actuators sn# start with an "S" and are 13 digits long, and call out a MAX 210 BAR pressure setting.

Helac Actuator



Helac Actuators sn# is only 6 digits and there is no additional marking



Helac	HKS
<p>D73060-2 (25 Spines) Actuator Shaft</p>  <p>D73060-3 Bearing Kit</p>  <p>D73060-1 Seal Kit</p> 	<p>D73060HKS-2 (19 Spines) Actuator Shaft</p>  <p>D73060HKS-3 Bearing Kit</p>  <p>D73060HKS-1 Seal Kit</p> 



Protective Safety Labeling

Perkins provides each finished cart lifter with ANSI-specified caution labels. They are clearly placed directly on the machine for easy viewing by the operators.

Should the cart lifter ever be re-painted, or if the labels are damaged beyond recognition, it is advised to replace the labels immediately to help keep your crew safe.

OHSA always requires these labels to be in clear sight on the machine.

Responsibility to maintain proper caution and warning labels is the responsibility of the end-user.



You should make sure that all pressure is bled/released from the hydraulic or pneumatic system; for some systems it may be possible to work on a part of the system by using line-breaking or blanking procedures. Never loosen or tighten a hydraulic connection when the system is under pressure. The connection could fail catastrophically and cause an injection injury and/or damage to property. Inspect hoses regularly for wear then replace hoses before leaks can develop. Hydraulics systems should look clean and dry. You can typically see leaks where the machine is collecting dirt and debris that is sticking to the oil. Look for wet-looking areas that are collecting dirt. Check for abraded/scuffed hoses, loose or damaged fittings, or worn out seals, or other physical damage that may have led to creating the leak.







Perkins Manufacturing Company
Creators of the TuckAway® Cart Lifter
www.perkinsmfg.com

800-882-5292

Revised:10/8/2020

Page 42 of 45

 	<p>⚠ CAUTION</p> <p>Pinch point hazard. Keep hands clear. Worker can be injured by moving parts.</p> <p>Skin injection hazard. Protect your hands & body from high pressure fluids. Relieve pressure before servicing. Do not check for leaks with your bare hands.</p>
<p>Compatible with ANSI Z245.60 type containers only.</p> <p>Cycle time must be 3-4 seconds up / 3-4 seconds down. Faster operation can cause damage and injury.</p>	
<p>Perkins Manufacturing. Company 708 482 9500 Label # D72589</p>	
 	<p>⚠ ATENCIÓN</p> <p>Punta Peligrosa. Mantenga las manos alejadas. El trabajador puede lesionarse moviendo partes.</p> <p>Riesgo de inyección cutánea. Proteja las manos y el cuero de liquidos en alta presión. Purgue la presión antes de realizar cualquier servicio. No busque fugas usando sus manos.</p>
<p>Compatible con ANSI Z245.60 solo contenedores de tipo.</p> <p>El tiempo del ciclo debe ser 3-4 segundos arriba / 3-4 segundos abajo. Una operación más rápida puede causar daños y lesiones.</p>	
<p>Perkins Manufacturing. Company 708 482 9500 Label # D72590</p>	

Dress appropriately for work with pants and sleeves that are not too long or too loose. Shirts should be fitted or tucked in. Avoid wearing loose and dangling jewelry. Tie back long hair and tuck braids and ponytails behind you or into your clothing. Wear the appropriate, well-fitting gloves for your job.

Look for possible pinch points before you start a task. Take the time to plan out your actions and decide on the necessary steps to work safely. Read and follow warning signs posted on equipment.

Machinery can pose a hazard with moving parts, conveyors, rollers, and rotating shafts. NEVER reach into a moving machine. Turn equipment off and use lockout/tagout procedures before adjusting, clearing a jam, repairing, or servicing a machine.



NOTICE

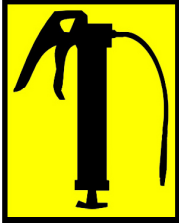

Grease all zerks on a weekly basis to maintain warranty.

Re-grease after power washing.

Visit www.perkinsmfg.com for important updates.

Please read the manual prior to operating or adjusting this machine for important information.

Perkins Manufacturing. Company 708 482 9500

Label # D72163

Maintaining the lifter is vital to ensure proper operation of the equipment and for warranty to be valid. Inspection of the lifter is also important to make sure there are no loose parts and that the lifter is properly greased. Not inspecting or maintaining the machine regularly can pose a hazard of parts coming loose, parts not moving properly or wear items to become too worn to not move properly. If any issues occur, please contact service immediately.



Perkins Manufacturing Company
Creators of the TuckAway® Cart Lifter
www.perkinsmfg.com

800-882-5292

Revised:10/8/2020

Page 44 of 45

Perkins Manufacturing Three-Year Limited Warranty

PERKINS MANUFACTURING COMPANY warrants its products to be free from defects in material and workmanship under normal use for a period of **three (3) years** from the date of delivery to the first purchaser.

Any claim under this warranty must be handled in accordance with PERKINS' warranty procedure.

This warranty is expressly limited to the repair or replacement in PERKINS' discretion of any component or part of any PERKINS product unit manufactured by PERKINS which is brought to PERKINS attention promptly after discovery and is proven to PERKINS' satisfaction to have been defective in material or workmanship.

This warranty shall not obligate PERKINS to bear the cost of labor or transportation charges in connection with the repair or replacement of defective parts, and it shall not apply to a product upon which repairs, or alterations have been made unless authorized in writing by PERKINS.

Any damage, wear & tear or improper use, substitution of parts not approved by PERKINS, modifications other than those done by PERKINS or as authorized in writing by PERKINS, or any alteration or repair by others in such a manner which, in PERKINS' judgment, materially and adversely affects the product shall void this warranty. Operation at an actuator cycle time of less than six seconds shall void this warranty. Wear items used for anti-friction purposes are not covered by this warranty.

Periodic maintenance is required in order to maintain warranty but is not covered by warranty. Please refer to the maintenance section of the service manual for instructions.

PERKINS makes no warranty of products manufactured by others and supplied by PERKINS, the same being subject to warranties, if any, of their respective manufacturers.

PERKINS shall not assume any liability for any incidental, consequential, direct, or indirect damage, loss or delay of any kind, including, but not limited to, the loss of profits, product or downtime.

PERKINS warrants any service parts it may sell for a period of ninety (90) day from the date of delivery for replacement only. The item being replaced must be returned to PERKINS for evaluation upon its request. The cost of labor to replace such part shall be the responsibility of the owner. PERKINS does not warrant any used parts.

PERKINS, whose policy is one of continuous improvement, reserves the right to improve its products through changes in design or materials as it may deem desirable without obligation to incorporate such changes in products of prior manufacture.

THE ABOVE WARRANTY SUPERCEDES AND IS IN LIEU OF ALL OTHER EXPRESS OR IMPLIED WARRANTIES INCLUDING, WITHOUT LIMITING, ANY IMPLIED WARRANTIES OF MERCHANTABILITY OR FITNESS FOR A PARTICULAR PURPOSE. NO EMPLOYEE OR ANY OTHER REPRESENTATIVE OF PERKINS IS AUTHORIZED TO CHANGE THIS WARRANTY IN ANY WAY OR TO GRANT ANY OTHER WARRANTY. THESE TERMS WILL BE CONSTRUED ACCORDING TO THE LAWS OF THE STATE OF ILLINOIS WITHOUT REGARD TO ITS CONFLICTS OF LAWS PROVISIONS. ALL ACTIONS OR PROCEEDINGS IN ANY WAY, MANNER OR RESPECT ARISING OUT OF OR RELATED TO THE GOODS WILL BE LITIGATED ONLY IN STATE OR FEDERAL COURTS, AS APPROPRIATE, LOCATED IN WILL COUNTY, ILLINOIS. BUYER CONSENTS AND SUBMITS TO JURISDICTION IN THE STATE OF ILLINOIS AND WAIVES ANY RIGHT TO TRANSFER THE VENUE OF ANY SUCH ACTION OR PROCEEDING.

